



Warrior

TO OUR CUSTOMER:

*Thank you for purchasing an **EverRide**® Warrior Zero Turn Mower. We believe that you have exercised excellent judgment in your selection. The Warrior has been designed to give you many years of satisfactory service. Successful operation and long life depends on proper maintenance and correct operating techniques.*

*Before you received your unit, the dealer has performed a pre-delivery inspection. The dealer will discuss with you the features, operation and maintenance requirements. Your dealer will always be there to help you any time you need assistance or need equipment related to the use of your **EverRide** mower.*

*We recommend that you carefully read this entire manual before operating the unit. This operator's manual has been printed to provide you with safe operating techniques, proper maintenance procedures, correct assembly, and parts identification on your **EverRide** Zero Turn Mower. Keep this manual handy for future reference.*

*Should any assistance be needed in understanding any section of this manual, contact your **EverRide** products dealer.*

This equipment is covered by a written warranty which will be provided to you in the pages following.

EverRide reserves the right to make changes or add improvements to its products without incurring any obligation to make such changes to products manufactured previously. **EverRide**, or its dealers, accept no responsibility for variations which may be evident in the actual specifications of its products and the statements and descriptions contained in the publication.



OWNER'S WARRANTY INFORMATION

This warranty applies to the original retail purchaser of the **EverRide**® products only. The warranty period starts upon the date of the original purchase reflected on the sales invoice.

As a condition to this warranty, the owner/operator shall have read, understood and followed the operator's manual guidelines for operations and maintenance supplied with this product, and that the product registration shall have been mailed to **EverRide**. Any lack of good maintenance, such as maintaining proper belt tension, tire pressures and lubrication shall be reason for rejection of a warranty claim.

In the judgment of **EverRide**, any original part found to be defective in material, workmanship or performance, will be repaired or replaced with a new part only by an **EverRide** Authorized Servicing Dealer without charge for parts and labor based on the following terms and conditions:

Warranty Coverage:

This warranty is limited to two years from the date of purchase for parts and one year for labor for any **EverRide** product used for commercial purposes, income producing purposes or residential use. **EverRide** products used for rental purposes are limited to 90 days of warranty. Engine and battery warranties are provided separately by the manufacturer of those components.

Belts, cutting blades, grass collection bags and tires are guaranteed to be free from manufacturer's defects for the first 90 days.

The mower deck shell will be warranted from cracking as a result of defects in material or workmanship for the life of the unit.

Service parts are warranted for 90 days from the date of purchase.

What this warranty does not cover:

The expense incurred for delivering this product to the dealer and returning it after repair. The responsibility of **EverRide** and its servicing dealers is limited to making the required repairs. Further, no breach of warranty shall be cause for cancellation of the contract of sale.

Subsequent purchasers of the mower other than the original purchaser. This warranty is not transferable.

Product(s) that has (have) been subject to improper maintenance, neglect, misuse, accident, alteration, modified or operated in any way contrary to the instructions specified in the Operator's Manual. Repairs made by unauthorized persons will not be covered under warranty. Damages caused by use of **EverRide** equipment other than for what it was designed.

Damages that are caused by unauthorized attachments, alterations or modifications will not be covered under warranty. Any piece of equipment where the serial number has been removed or is made illegible will not be covered under warranty.

Wear or maintenance items (unless defective) including, but not limited to: Clutch and brake linings, light bulbs, grass bags, filters (air, fuel, oil), lubricants & coolants (unless used during an authorized repair), spark plugs, injector nozzles.

As the manufacturer of this product, **EverRide** reserves the right to change, modify or improve the design of any of its products without assuming any obligation to modify or upgrade any mower, previously sold or manufactured.

As stated above, all other implied warranties are limited in duration. Any such implied warranties including merchant ability, fitness for a particular purpose, or otherwise, are disclaimed in their entirety after the expiration of the warranty period. **EverRide's** obligation to the original owner is strictly and exclusively limited to the repair or replacement of defective parts, and **EverRide** does not assume nor authorize anyone to assume for them any other obligation.

EverRide assumes no responsibility for incidental, consequential or other damages including, but not limited to: Transportation of the mower to an Authorized Dealer and returning it back, rental of truck or trailer for transportation, expense for gasoline, injury to property, mechanic's travel time and mileage to perform repair(s), rental of a like product, loss of use of the **EverRide** product, loss of savings or revenue, loss or damage to personal property, and/or telephone charges.

Exclusions or limitations as stated above may not be allowed in some states. This warranty allows you specific legal rights and you may have other rights in your state.

Warranty Registration

The warranty registration form must be completed and signed by the authorized dealer and the original purchaser and returned to **EverRide** within ten days of the date of purchase. The date of purchase is considered the day the unit is delivered.

Dealer or Distributor Warranties

The selling dealer and distributor makes no warranty of their own and neither the dealer nor the distributor has any authority to make any representation or promise on behalf of **EverRide**, or to modify the terms or limitations of this warranty in any way.

**EverRide Warrior
Operator's & Parts Manual
CONTENTS**

| | |
|---|-----------|
| SAFETY..... | 1 |
| PERSONAL SAFETY INSTRUCTIONS..... | 1 |
| SAFE OPERATING PRACTICES..... | 1 |
| TRAINING..... | 1 |
| PREPARATION..... | 1 |
| OPERATION..... | 2 |
| MAINTENANCE AND STORAGE..... | 2 |
| EVERRIDE MOWER SAFETY..... | 3 |
| GENERAL SAFETY RULES..... | 3 |
| KEEP PASSENGERS OFF..... | 4 |
| BEFORE OPERATION..... | 4 |
| DURING OPERATION..... | 5 |
| OPERATING ON SLOPE..... | 6 |
| ROLL OVER PROTECTIVE STRUCTURE..... | 6 |
| SEAT BELT USAGE..... | 7 |
| MAINTENANCE..... | 7 |
| FUEL SYSTEM..... | 7 |
| HYDRAULIC SYSTEM..... | 8 |
| BATTERY MAINTENANCE..... | 8 |
| TIRE MAINTENANCE..... | 9 |
| REPLACEMENT PARTS..... | 9 |
| TRANSPORTING..... | 9 |
| SAFETY & INSTRUCTION DECALS..... | 11 |
| INTRODUCTION..... | 12 |
| IDENTIFICATION..... | 13 |
| MODEL/SERIAL NUMBERS..... | 13 |
| INSTRUMENTS & CONTROLS..... | 14 |
| INSTRUMENT PANEL..... | 15 |
| ELECTRIC FUEL SHUT OFF..... | 15 |
| IGNITION SWITCH..... | 15 |
| ENGINE THROTTLE..... | 15 |
| CHOKE..... | 15 |
| PTO ENGAGEMENT..... | 16 |
| HOUR METER..... | 16 |
| COMFORT ADJUSTMENTS..... | 16 |
| OPERATING THE POWER UNIT..... | 17 |
| BREAK -IN PERIOD..... | 17 |
| MOUNTING AND DISMOUNTING SAFELY..... | 17 |
| FUEL..... | 17 |
| SWITCHING FUEL TANKS..... | 17 |
| STARTING THE EVERRIDE MOWER..... | 18 |
| Pre Start Inspection..... | 18 |
| Normal Starting..... | 18 |
| Starting in Cold Weather..... | 19 |
| Jump Starting the Power Unit..... | 19 |
| WARMING THE ZERO TURN MOWER..... | 19 |
| INCREASING ACCELERATION..... | 20 |

ii - CONTENTS

| | |
|---|-----------|
| LOCKING THE FRONT AXLE..... | 20 |
| RAISING THE MOWER DECK..... | 20 |
| OPERATING THE EVERRIDE MOWER..... | 20 |
| STEERING CONTROLS..... | 20 |
| STOPPING THE ENGINE..... | 21 |
| MOVING A STALLED EVERRIDE MOWER..... | 21 |
| TOWING WITH AN EVERRIDE MOWER..... | 21 |
| PARKING THE POWER UNIT..... | 22 |
| LOADING THE MOWER..... | 22 |
| TRANSPORTING THE MOWER..... | 22 |
| OPERATING THE MOWER. | 23 |
| GENERAL INFORMATION..... | 23 |
| OPERATING A SIDE DISCHARGE MOWER..... | 23 |
| TIPS FOR EFFICIENT MOWING..... | 25 |
| CUTTING HEIGHTS..... | 24 |
| ADJUSTING THE MOWER HEIGHT OF CUT..... | 24 |
| GAUGE WHEEL ADJUSTMENT..... | 24 |
| UNEVEN TERRAIN..... | 25 |
| GRASS DISCHARGE..... | 26 |
| PARTS. | 26 |
| LUBRICATION AND MAINTENANCE. | 27 |
| SPECIFICATIONS AND CAPACITIES..... | 27 |
| LUBRICATION/FILL POINTS..... | 28 |
| PERIODIC MAINTENANCE SCHEDULE..... | 29 |
| AVOID FUMES..... | 30 |
| SERVICE ACCESS..... | 30 |
| ENGINE OIL LEVEL..... | 30 |
| CHANGING THE ENGINE OIL..... | 31 |
| OIL FILTER CHANGE..... | 31 |
| HYDROSTATIC MAINTENANCE..... | 32 |
| CHANGING THE HYDRAULIC FLUID..... | 32 |
| BLEEDING THE HYDRAULICS..... | 32 |
| CHECKING THE HYDRAULIC HOSES..... | 33 |
| BATTERY MAINTENANCE..... | 33 |
| REMOVING THE BATTERY..... | 33 |
| CHARGING THE BATTERY..... | 34 |
| CLEANING THE BATTERY AND TERMINALS..... | 35 |
| REPLACING THE FUSES..... | 35 |
| SAFETY CHECKS..... | 35 |
| CHECKING THE KILL CIRCUITS..... | 35 |
| LIFT ASSIST SPRING..... | 35 |
| NEUTRAL ADJUSTMENT..... | 35 |
| SERVICING THE CASTER WHEEL ROLLER BEARINGS..... | 36 |
| SERVICING THE CASTER PIVOT BEARINGS..... | 36 |
| MOTION CONTROL ADJUSTMENT..... | 37 |
| LEVELING THE DECK..... | 37 |
| SYNCHRONIZING HEIGHT OF CUT..... | 38 |
| DRIVE ADJUSTMENTS..... | 38 |
| ENGINE AIR CLEANER SERVICE..... | 38 |
| FUEL SYSTEM SERVICE..... | 39 |
| SPARK PLUG SERVICE..... | 40 |

| | |
|--|-----------|
| COOLING SYSTEM CLEANING..... | 41 |
| SEASONAL STORAGE..... | 41 |
| FUEL SYSTEM DRAINING..... | 41 |
| TIRE AND WHEEL MAINTENANCE..... | 42 |
| BLADE MAINTENANCE..... | 42 |
| CLEANING GRASS BUILDUP FROM DECK..... | 43 |
| BELT REPLACEMENT..... | 43 |
| DECK BELT REPLACEMENT..... | 44 |
| PUMP BELT REPLACEMENT..... | 45 |
| BOLT TORQUE CHART..... | 46 |
| HYDRAULIC SCHEMATIC..... | 47 |
| ELECTRICAL SCHEMATIC..... | 48 |
| TROUBLESHOOTING..... | 49 |
| MOWER TROUBLESHOOTING GUIDE..... | 49 |
| POWER UNIT TROUBLESHOOTING GUIDE..... | 51 |
| MOWER ASSEMBLY INSTRUCTIONS..... | 53 |
| SETUP INSTRUCTIONS..... | 53 |
| SEALED BATTERY INSTALLATION..... | 53 |
| HYDRAULIC OIL SERVICE..... | 53 |
| ASSEMBLING THE FIXED ROPS..... | 53 |
| ASSEMBLING THE FOLDING ROPS..... | 53 |
| ATTACHING THE ROPS TO THE TRACTOR..... | 54 |
| SPECIFICATIONS..... | 55 |
| EVERRIDE WARRIOR MOWER..... | 55 |
| ENGINE..... | 55 |
| ELECTRICAL SYSTEM..... | 55 |
| DIMENSIONS..... | 55 |
| TRAVELING SYSTEM..... | 56 |
| PTO..... | 56 |
| MOWER..... | 56 |
| PARTS PAGES..... | 57 |
| EVERRIDE MOWER SAFETY DECALS..... | 10 |
| MOWER DECK SAFETY DECALS..... | 11 |
| MOWER DECK GROUP..... | 60 |
| FRONT WHEEL ASSEMBLY..... | 64 |
| REAR LIFT ROD ASSEMBLY..... | 66 |
| SPINDLE ASSEMBLY..... | 68 |
| HANDLE ASSEMBLY..... | 70 |
| AIR FILTER ASSEMBLY..... | 70 |
| CONTROL PANEL ASSEMBLY..... | 72 |
| FULL VISION ROPS..... | 72 |
| FEMCO ROPS..... | 74 |
| HYDRAULIC PUMP ASSEMBLY..... | 74 |
| CLUTCH ASSEMBLY..... | 76 |
| TIRE & BUMPER ASSEMBLY..... | 78 |
| FRONT AXLE TO FRAME ASSEMBLY..... | 80 |
| WHEEL MOTOR ASSEMBLY..... | 82 |
| ELECTRIC COMPONENTS..... | 84 |
| FUEL COMPONENTS..... | 86 |
| HYDRAULIC COMPONENTS..... | 88 |

iv - CONTENTS

| | |
|--|------------|
| SEAT & FOOT PLATE ASSEMBLY..... | 90 |
| DECK ATTACHMENT COMPONENTS..... | 92 |
| DECK LIFT COMPONENTS..... | 94 |
| PUMP COMPONENTS..... | 96 |
| BRIGGS & STRATTON ENGINE COMPONENTS..... | 96 |
| ENGINE ATTACH COMPONENTS..... | 98 |
| MOTION CONTROL ASSEMBLY..... | 100 |
| | |
| PARTS LIST..... | 104 |
| | |
| SLOPE GUIDE..... | 107 |
| | |
| MAINTENANCE RECORDS..... | 108 |



SAFETY FIRST

This symbol, the industry's "Safety Alert Symbol", is used throughout this manual and on labels on the machine itself to warn of the possibility of personal injury. Read these instructions carefully. It is essential that you read the instructions and safety regulations before you attempt to assemble or use this unit.



DANGER: Indicates an immediately hazardous situation which, if not avoided, will result in death or serious injury.



WARNING: Indicates a potentially hazardous situation which, if not avoided, could result in death or serious injury.



CAUTION: Indicates a potentially hazardous situation which, if not avoided, may result in minor or moderate injury.

IMPORTANT: Indicates that equipment or property damage could result if instructions are not followed.

NOTE: Gives helpful information.

This machine meets or exceeds the B71.4 2004 specifications of the American National Standards Institute, in effect at the time of production.

Note: The addition of attachments made by other manufacturers that do not meet the American National Standards Institute certification will cause noncompliance of this machine.

SAFE OPERATING PRACTICES

The following instructions are from ANSI standard B71.4 - 2004.

TRAINING

Read the Operator's Manual and other training material. If the operator(s) or mechanic(s) cannot read English, it is the owner's responsibility to explain this material to them.

Become familiar with the safe operation of the equipment, operator controls, and safety signs.

All operators and mechanics should be trained. The owner is responsible for training the users.

Never let children or untrained people operate or service the equipment. Local regulations may restrict the age of the operator.

The owner/user can prevent and is responsible for accidents or injuries occurring to themselves, other people or property.

PREPARATION

Evaluate the terrain to determine what accessories and attachments are needed to properly and safely perform the job. Only use accessories and attachments approved by the manufacturer.

Wear appropriate clothing including hard hat, safety glasses and ear protection. Long hair, loose clothing or jewelry may be tangled in moving parts.

Inspect the area where the equipment is to be used and remove all objects such as rocks, toys and wire, which can be thrown by the machine.

2 - SAFETY

Use extra care when handling gasoline and other fuels. They are flammable and vapors are explosive.

- a. Use only an approved container.
- b. Never remove gas cap or add fuel with engine running. Allow engine to cool before refueling. Do not smoke.
- c. Never refuel or drain the machine indoors.

Check that operator's presence controls, safety switches and shields are attached and functioning properly. Do not operate unless they are functioning properly.

OPERATION

Never run an engine in an enclosed area.

Only operate in good light, keeping away from holes and hidden hazards.

Be sure all drives are in neutral and parking brake is engaged before starting the engine. Only start engine from the operator's position. Use seat belts if provided and the ROPS is installed.

Slow down and use extra care on hillsides. Be sure to travel in the recommended direction on hillsides. Turf conditions can affect the machine's stability. Use caution while operating near drop-offs.

Slow down and use caution when making turns and when changing directions on slopes.

Never raise deck with the blades running.

Never operate with the PTO shield, or other guards not securely in place. Be sure all interlocks are attached, adjusted properly, and functioning properly.

Never operate with the discharge shield raised, removed or altered, unless using a grass catcher.

Do not change the engine governor setting or over speed the engine.

Stop on level ground, lower implements, disengage drives, engage parking brake (if provided), shut off engine before leaving the operator's position for any reason including emptying the catchers or unclogging the chute.

Stop equipment and inspect blades after striking objects or if an abnormal vibration occurs. Make necessary repairs before resuming operations.

Keep hands and feet away from the cutting units.

Look behind and down before backing up to be sure of a clear path.

Never carry passengers and keep pets and bystanders away.

Slow down and use caution when crossing roads and sidewalks.

Stop blades if not mowing.

Be aware of the mower discharge direction and do not point it at anyone.

Do not operate the mower under the influence of alcohol or drugs.

Use care when loading or unloading the machine into a trailer or truck.

Use care when approaching blind corners, shrubs, trees, or other objects that may obscure vision.

MAINTENANCE AND STORAGE

Disengage drives, lower implement, set parking brake, stop engine and remove key or disconnect spark plug wire. Wait for all movement to stop before adjusting, cleaning or repairing.

Clean grass and debris from cutting units, drives, mufflers, and engine to help prevent fires. Clean up oil or fuel spillage.

Let engine cool before storing and do not store near flame.

Shut off fuel while storing or transporting. Do not store fuel near flames or drain indoors.

Park the machine on level ground. Never allow untrained personnel to service machine.

Use jack stands to support components when required.

Carefully release pressure from components with stored energy.

Disconnect battery or remove spark plug wire before making any repairs. Disconnect the negative terminal first and the positive last. Reconnect positive first and negative last.

Use care when checking blades. Wrap the blade(s) or wear gloves, and use caution when servicing them. Only replace blades. Never straighten or weld them.

Keep hands and feet away from moving parts. If possible, do not make adjustments with the engine running.

Charge batteries in an open well ventilated area, away from spark and flames. Unplug charger before connecting or disconnecting from battery. Wear protective clothing and use insulated tools.

Keep all parts in good working condition and all hardware tightened. Replace all worn or damaged decals.

EVERRIDE MOWER SAFETY

The following list of safety warnings are specific to **EverRide** products. This list will contain additional safety information that is important, but not covered by the ANSI standards.

This product is capable of amputating hands and feet and throwing objects. Always follow all safety instructions to avoid serious injury or death.

The safety of the operator is one of our number one concerns when designing a new piece of

equipment. Our designers have built in as many safety features as possible. Even with these built in safety features, many accidents occur which could have been avoided by a few seconds of thought and a more careful approach to handling machinery. Accidents can be avoided by observing all safety precautions. Read and understand all precautions found in the operator's manual before operating the **EverRide** mower. This equipment must only be operated by those who have been trained in its safe use.

In order to provide a better view, certain photographs or illustrations in this manual may show an assembly with a safety shield removed. However, a machine should never be operated without the safety shields installed. Keep all shields in place. If shield removal becomes necessary for repairs, replace shield prior to machine operation.



WARNING: DO NOT remove or obscure DANGER, WARNING, CAUTION or Instruction Decals. Replace any decals that are not readable or are missing. Replacement decals are available from your dealer. The actual location of these Safety Decals is illustrated at the end of this section.

GENERAL SAFETY RULES

This book must be made available to the operator of the **EverRide** mower at all times.

Read this book carefully and learn how to use the machine correctly. Become familiar with all machine controls and how to stop the machine and the implements or attachments quickly.



4 - SAFETY

Beware of bystanders, particularly children!

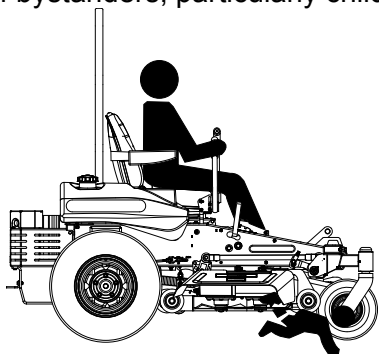

Always look around to make sure that it is safe to start the engine or move the power unit. This is particularly important with higher noise levels as you may not hear people shouting.

KEEP PASSENGERS OFF

Only allow the operator on the machine. Do not carry passengers. This mower is designed for one (1) person, the driver.

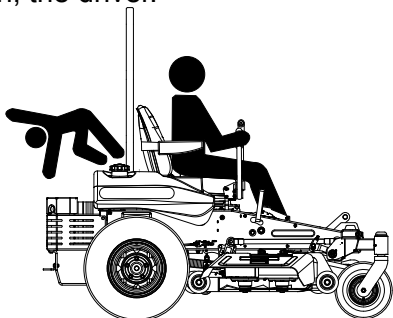

Riders on the machine could be struck by foreign objects or thrown off the machine causing serious injury.



Riders obstruct the operator's view which results in the machine being operated in a manner which is unsafe.

DO NOT carry passengers anywhere on the power unit or on any implement or attachment connected to, or installed on the power unit.

BEFORE OPERATION

Pay special attention to the warning, caution and danger labels on the machine.

Do not use starting fluid. Use of starting fluid could damage engine components.



Check the brakes and other mechanical parts for correct adjustment and wear. Replace worn or damaged parts promptly. Check the torque on all hardware regularly.

Do not wear headphones or listen to music while operating the deck. Operating the machinery safely requires your undivided attention.

Keep the power unit and attachments clean. Accumulation of dirt, grease, or grass can lead to fires or personal injury.

Do not modify the power unit or any of its attachments. Unauthorized modification of the machinery may affect its functionality, which could lead to personal injury.

Do not wear loose fitting clothing which could get caught in moving parts. Do not operate this machine while wearing shorts. Always be sure to wear adequate protective clothing. Wearing safety glasses and safety shoes is advisable.

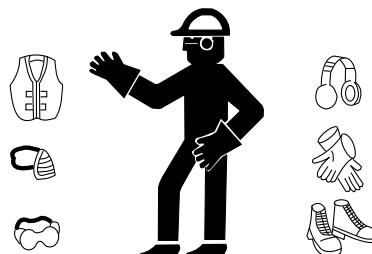

Operator hearing protection is recommended. Extended exposure to loud noise could lead to hearing loss.

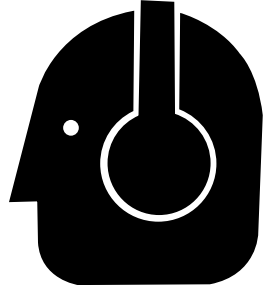

Never remove the discharge shield from the mower because the discharge shield directs material down toward the turf. If the shield is damaged, be sure to replace it immediately.

Never try to clear the discharge area or the mower blades unless you have moved the motion control arms to the park position, turned the mower PTO switch to the off position, the mower ignition switch is in the off position, the key is removed and the negative battery cable has been removed.

A fire extinguisher and first aid box should be carried with the power unit or be kept readily available at all times.

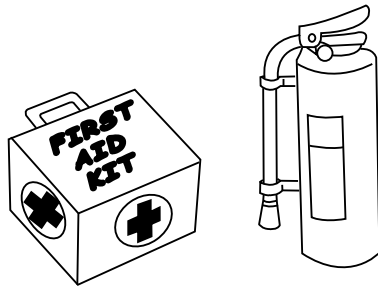

Do not operate the power unit in a confined or non-ventilated area. Carbon monoxide gas is colorless, odorless, and can be fatal.

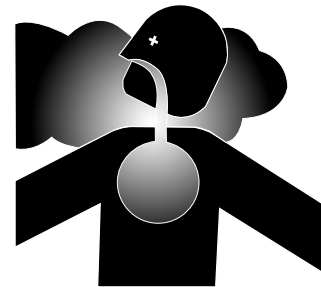

Keep emergency numbers for immediate access.

Do not turn sharply when driving at high speeds.

DURING OPERATION

Park the mower on a firm level surface with the motion control arms in the park position.

Do not bypass the starting circuit by shorting across the terminals of the starter motor to start the engine. This may cause the power unit to move suddenly.

When backing, be sure to turn around and look to the rear. Do not mow in reverse unless it is absolutely necessary.

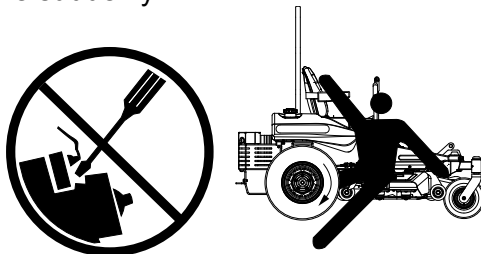

When working in groups, use caution and watch out for others.

Always be aware of mower discharge direction. Make sure it does not point at anyone.

Periodically check the starting circuit to make sure all system components operate correctly.

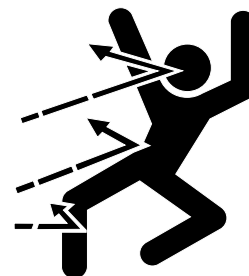

If the starting system does not work, consult your EverRide Dealer immediately.

Operate the mower only in daylight or when the area to be mowed is lit well by artificial light.

6 - SAFETY

Be sure the engine and rotating blades have stopped before putting hands or feet near the blade.

Disengage the blade drive when transporting the machine across drives, sidewalks, etc. Never raise the mower deck while the blades are turning.

Do not put hands or feet under or into the mower when it is running.

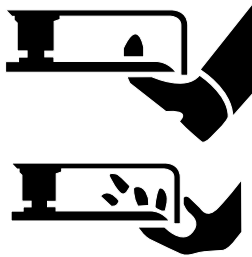

Do not touch the engine or muffler when the engine is running or immediately after the engine has stopped. These areas may be hot enough to cause serious burns.

Do not drive the machine on streets or highways. Watch for traffic when crossing streets or while mowing close to roads.

Always inspect the mower for damage after striking a foreign object. Always repair or replace damaged parts before restarting the mower deck.

Do not operate the power unit without the mower deck attached.

Make sure the machine and all attachments come to a complete stop before dismounting.

Before dismounting, disengage the PTO, lower all attachments, place the control levers in the park position, turn off the engine, and remove the key.

OPERATING ON SLOPES

Avoid starting or stopping when going up or down a slope. Keep all movements on a slope gradual

and slow. Do not make sudden changes in speed or direction.

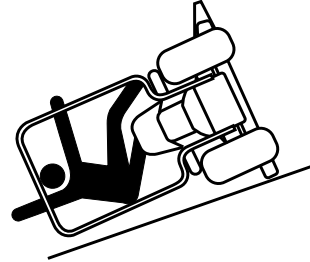

If tires lose traction while on a slope, disengage the mower blades and back slowly and gradually down the slope.

Do not turn on slopes unless necessary, and then turn slowly and gradually downhill if possible.

Use extra caution when mowing on slopes. If you are unable to back up on the slope, or if you do not feel comfortable on it, then do not mow it. Do not operate the machine on slopes that exceed 15°.

Mow across slopes, not up and down, to avoid machine tip-over. Do not mow slopes or hills that are too steep for safe operation.

Do not try to stabilize the machine by putting your foot on the ground.

ROLL OVER PROTECTIVE STRUCTURE (ROPS)

Do not weld, drill or alter the ROPS. Damaged ROPS must not be straightened or used. If damage does occur, consult your EverRide Dealer and replace all damaged parts.

If the ROPS is lowered or removed from the power unit for any reason, it must be erected and/or refitted immediately. Original bolts or equivalent replacements must be used and tightened to the correct torque.

Do not attach chain, ropes, or cables to the ROPS for pulling purposes as this will cause the mower to tip backwards.

EverRide does not recommend the use of the mower with the ROPS removed.

If you have a foldable ROPS, it can be folded down for mower storage. It **must** be pinned in the upright position prior to machine operation.

SEAT BELT USAGE

With the ROPS installed, it is imperative that the seat belt be installed, used, and correctly adjusted at all times. Replace damaged seat belts immediately.

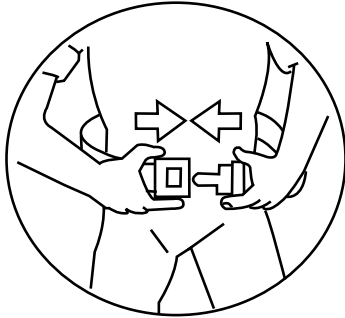

Do not use a seat belt if operating with ROPS folded down or removed.

MAINTENANCE

Only qualified, trained adults should service the machine.

Before maintenance is performed, make sure the mower is parked on a firm flat surface. Remove the key to prevent an accidental start up.

Never attempt to disconnect any safety devices.

Frequently check for worn or deteriorating components that could create a hazard.

Use only genuine **EverRide** replacement parts. Substitute parts could cause product malfunction or possible injury to the operator or bystanders.

If it is necessary to have the engine running while making maintenance adjustments, keep hands, feet, and clothing away from all moving parts.

When making adjustments while the engine is running such as carburetor and motion control linkage adjustments, stand to either side of the tractor and mower and keep clear of moving or rotating components.

Allow the **EverRide** mower time to cool before touching the engine, the muffler, radiator, or any other part which may be hot.

Always stop the power unit and PTO before refueling.

Keep the engine free of grass, leaves, grease and other debris which could catch fire.

Keep all hardware tight to insure the machine is in a safe working condition. Check the blade mounting nuts often to make sure they are tight.

Perform only maintenance instructions described in this manual. Unauthorized maintenance operations or machine modifications may result in unsafe operating conditions.

For engine maintenance, follow the engine manufacturer's recommendations as noted in the engine manual.

FUEL SYSTEM

Handle gasoline with care. Gasoline is extremely flammable and its vapors can be explosive. Use an approved fuel container.

Never add fuel to the mower while the engine is running or while it is hot. Allow the engine to cool for several minutes before adding fuel.

Keep matches, cigarettes, cigars, pipes, open flames, or sparks away from the fuel tank and fuel container.

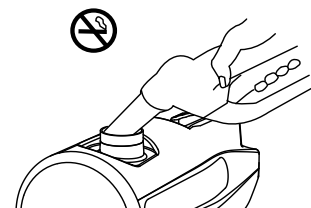

8 - SAFETY

Always fill the fuel tanks outside using caution. Fill the tank until the fuel is about one inch from the top of the tank. Use a funnel or spout to prevent spilling. When refueling at a gas pump, always insure the nozzle contacts the neck of the tank while filling.

Replace the machine and container caps and clean up any spilled fuel before starting the engine.

Keep the mower and all fuel containers in a safe locked place to keep children from tampering with them.

Fuel system components rely upon clean fuel for lubrication and optimum performance. Extreme care must be taken to prevent ingress of dirt and moisture to prevent damage.

Use only nonmetal portable fuel containers approved by the Underwriter's Laboratory (U.L.) or the American Society for Testing and Materials (ASTM). If using a funnel, make sure it is plastic and has no screen or filter.

When practical, do not fuel the equipment on truck beds or on trailers. Remove them and fuel on the ground. If this is not possible, use a portable nonmetal fuel container to fill the equipment.

HYDRAULIC SYSTEM

Make sure all hydraulic fluid, hoses, and lines are in good condition and all lines and fittings are tight before applying pressure to the hydraulic system.

Check hydraulic connections frequently. They can leak as a result of damage, as a result of vibration or because they have worked loose.

Relieve all pressures before disconnecting hoses or lines. Escaping oil under pressure can cause serious injury.

Escaping hydraulic fluid under pressure can have sufficient force to penetrate the skin, causing serious injury. Before applying pressure to the system,

make sure all connections are tightened, and lines, pipes and hoses are not damaged. Fluid escaping from pinholes may be invisible. Do not use your hands to search for suspected leaks. Instead, use a piece of cardboard and wear protective eye wear such as safety goggles.

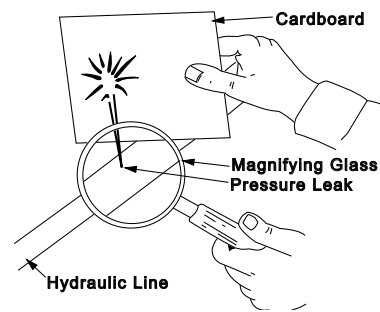

If injured by escaping fluid, see a medical doctor at once. Serious infection or reaction will result if proper medical treatment is not administered immediately. This fluid can produce gangrene or severe allergic reaction.

BATTERY MAINTENANCE

Use caution when charging the battery or performing maintenance on the battery and electrical system.

Do not use a naked flame to check battery electrolyte level. Always use a voltmeter or hydrometer to check the state of the charge.

Make sure the battery charger is unplugged before connecting or disconnecting the cables to the battery.

Batteries contain sulfuric acid electrolyte. Always wear protective clothing and eye protection when servicing.

In case of electrolyte contact, rinse area with plenty of water and seek medical attention.

Make sure the battery is charged in a well ventilated location so hydrogen gases that are produced while it is charging can dissipate. Make sure the battery vents in the cap are open. Halt charging if battery exceeds 52°C (125°F).

Keep sparks, flames, and smoking material away from the battery at all times. To avoid sparks, use care when removing battery cables from their posts.

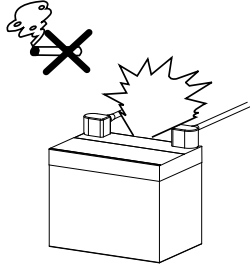

Do not use or charge the refillable type of battery if the fluid level is below the lower limit level mark. Otherwise the parts may prematurely deteriorate which could shorten the battery's service life or cause an explosion.

Before "jump starting" a battery, read and understand all instructions.

Disconnect the battery's ground cable before working on or near any electrical parts.

TIRE MAINTENANCE

Always insure the tires are inflated to the correct pressure. Do not inflate the tires above the recommended pressure in the operator's manual.

Make sure all hardware, especially the wheel nuts and bolts have been tightened to the correct torque.

When removing a tire from the power unit, it is necessary to support it with blocks or stands, not a hydraulic jack.

Do not attempt to service a tire unless you have the proper equipment and experience to perform the job. If you are not qualified to make the repairs, take the unit to your EverRide dealer or a qualified repair service.

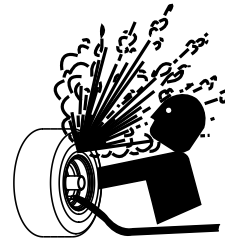

When seating tire beads on the rims, never exceed 2, 4 bar (35 p.s.i.) or the maximum inflation specified on your tires. Inflation beyond this maximum pressure may break the bead, or even the rim, with dangerous explosive force.

REPLACEMENT PARTS

Where replacement parts are necessary for periodic maintenance and servicing, genuine EverRide replacements must be used to restore your equipment to original specifications.

EverRide will not claim responsibility for installation of unapproved parts and/or accessories and damages as a result of their use.

TRANSPORTING

Disengage the power to the attachments when in transport or not in use.

Do not tow this machine. Use a truck or trailer to transport this machine on public roads.

It is recommended this machine not be used on public roads.

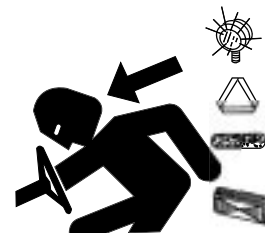

Flashing warning lights and a slow moving vehicle sign are recommended any time the mower is driven on public roads.

Slow moving vehicles are difficult to see on public roads especially at night. Use extreme caution when transporting at night.

10 - SAFETY & INSTRUCTION DECALS

Made with Pride
In the

USA Auburn, NE

EverRide

WARNING

TO AVOID SERIOUS INJURY OR DEATH
1. USE EXTREME CAUTION WHEN OPERATING ON SLOPES.
2. MOW ACROSS SLOPES - NOT UP AND DOWN.
3. DRIVE SLOWLY ON SLOPES.
4. AVOID SUDDEN STARTS.
5. DO NOT OPERATE ON WET SLOPES.
6. EXERCISE TURNING SLOWLY.
7. LOSS OF TRACTION MAY OCCUR WHEN OPERATING ON SLOPES.
8. NEVER CARRY CHILDREN OR OTHERS.
9. KEEP SAFETY DEVICES (GUARDS, SHIELDS AND SWITCHES) IN PLACE AND WORKING.
10. REMOVE OBJECTS THAT COULD BE THROWN BY THE BLADE.
READ AND UNDERSTAND OPERATOR'S MANUAL.

WARNING
TO AVOID THE POSSIBILITY OF INJURY
1. READ AND UNDERSTAND ALL SAFETY AND INSTRUCTION LABELS ON THIS EQUIPMENT, AS WELL AS ALL SAFETY PRECAUTIONS FOUND IN THE OPERATOR'S MANUALS FOR THIS EQUIPMENT, BEFORE ITS USE.
2. DO NOT MODIFY OR ALTER, OR PERMIT ANYONE ELSE TO MODIFY OR ALTER THIS EQUIPMENT, OR ANY OF ITS COMPONENTS OR OPERATING FUNCTIONS, WITHOUT THE EXPRESS WRITTEN PERMISSION OF THE EQUIPMENT MANUFACTURER.

CAUTION
TO AVOID PERSONAL INJURY
1. KNOW LOCATION AND FUNCTION OF ALL CONTROLS.
2. BEFORE STARTING ENGINE, MAKE CERTAIN PTO IS DISENGAGED, MOTION CONTROL LEVER IS NEUTRAL LOCK AND EVERYONE IS AT A SAFE DISTANCE FROM THE MACHINE.
3. TO REDUCE FIRE HAZARD, KEEP THE FORWARD CLEAR OF DRY GRASS, DRY LEAVES OR OTHER COMBUSTIBLE MATERIALS.
4. BEFORE DISMOUNTING, DISENGAGE PTO CLUTCH, LOWER IMPLEMENT, SHIFT INTO NEUTRAL, SET PARKING BRAKE, STOP ENGINE AND REMOVE KEY.
5. THIS MACHINE IS NOT FOR STREET OR HIGHWAY USE.
READ AND UNDERSTAND OPERATOR'S MANUAL.

1. 191214

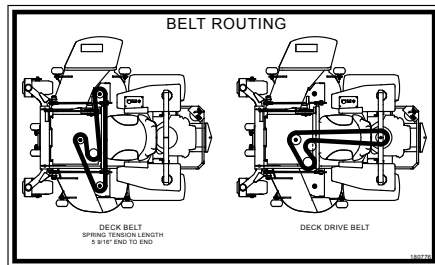

6. 180776

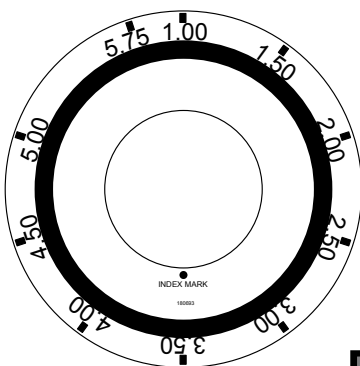

9. 180693

WARNING

- Shield Missing.
- DO NOT Operate.

12. 160169



13. 181000

54

15. 181367 - 54"
181368 - 60"
181719 - 66"



2. 181003

ATTENTION

- Hydraulic Oil -
SAE 20W50 SJ/CD

Fill Until Oil Covers
Top Of Baffle

Use Of Non-Recommended
Oils Could Cause Damage

4. 181254

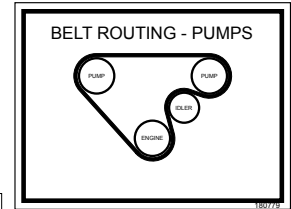

3. 180779

DECK RELEASE LEVER
DEPRESS FOOT LIFT BEFORE RELEASING

5. 180846



8. 180954

DANGER!



7. 180996

LUBRICATION INTERVALS

| REF | DESCRIPTION | FREQUENCY |
|-----|------------------------|-----------|
| 1 | BLADE SPINDLES (3) | 25 HOURS |
| 2 | DECK PIVOT IDLER (1) | 25 HOURS |
| 3 | PUMP DRIVE TENSION (1) | 25 HOURS |
| 4 | FRONT WHEEL AXLES (2) | 40 HOURS |
| 5 | LIFT LINK PIVOTS (2) | 40 HOURS |
| 6 | FRONT AXLE PIVOT (1) | 40 HOURS |
| 7 | DRAG LINK PIVOTS (2) | 40 HOURS |
| 8 | HYDRAULIC FLUID LEVEL | DAILY |
| 9 | ENGINE OIL LEVEL | DAILY |
| 10 | WHEEL FORK PIVOTS (2) | YEARLY |

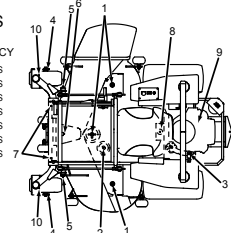

10. 181253

DANGER

ROTATING BLADE
DO NOT PUT HANDS OR FEET UNDER OR INTO MOWER WHEN ENGINE IS RUNNING

THROWN OBJECTS
BEFORE MOWING, CLEAR AREA OF PEOPLE AND OBJECTS THAT MAY BE THROWN BY BLADE

DO NOT OPERATE MOWER WITHOUT ENTIRE GRASSCATCHER IN PLACE OR DISCHARGE CHUTE IN PLACE AND IN LOWERED POSITION

FAILURE TO COMPLY WILL RESULT IN DEATH OR SERIOUS INJURY



11. 181258



14. 181441

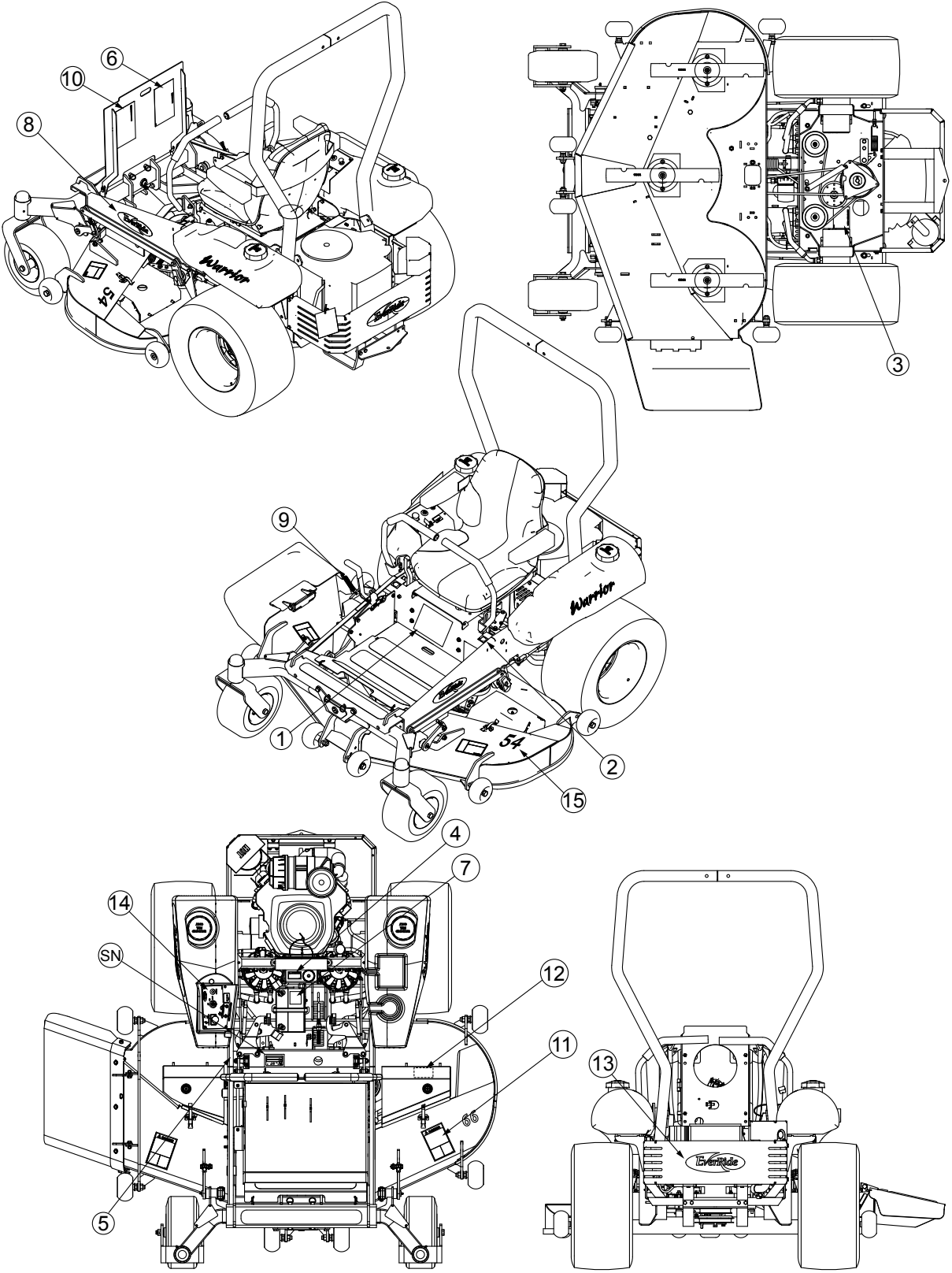

12 - INTRODUCTION

INTRODUCTION

The information in this publication describes the operation, maintenance and servicing of the **EverRide** Warrior mowers. Every effort has been made to provide correct and concise information to you, the operator, as available at date of book publication. Your **EverRide** dealer is available should items in this book or details of your machine not be understood.

This book is supplied with each machine to familiarize the operator with proper instructions needed for operation and maintenance. Studying and adhering to these instructions will insure optimum machine performance and longevity. A machine that is maintained properly and operated in the intended manner will provide greater dividends than one that is neglected and/or operated in manner other than as intended. Design and servicing of this machine has been kept as simple as possible to permit maintenance operations to be carried out with tools normally available.

This book should be thoroughly read and understood prior to operation of this machine. Inexperienced operators should study the contents of this publication and receive instruction from an experienced operator when possible. Your **EverRide** dealer can also assist in areas concerning machine operation and provide details concerning safe operation. It is suggested that this booklet be kept readily accessible, preferably with the machine, for future reference if questions or concerns arise. If the original book should become damaged, consult your Dealer in regards to acquiring a replacement.

Customers are strongly advised to use an official **EverRide** dealer in connection with any service problems and adjustments that may occur. The **EverRide** dealer network is specially trained and equipped for all service work and to advise customers on specific applications of the mower in local conditions.

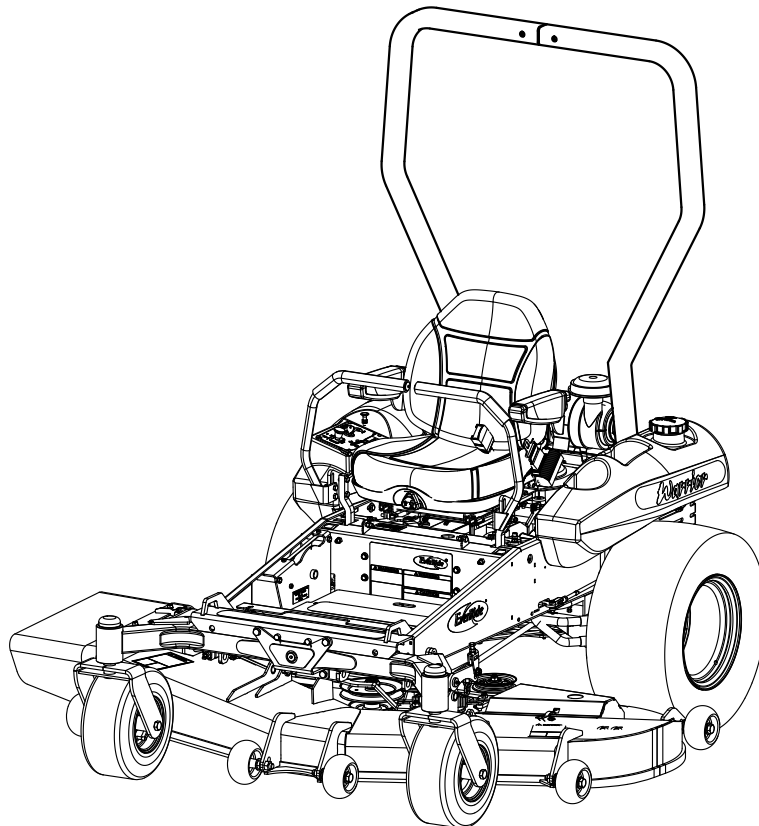

IDENTIFICATION

Model / Serial Numbers

Each EverRide Warrior mower is identified by means of model and serial numbers. As a further identification, the engine is also provided with identification numbers.

To insure prompt, efficient service when ordering parts or requesting repairs from an authorized EverRide dealer, these numbers must be provided.

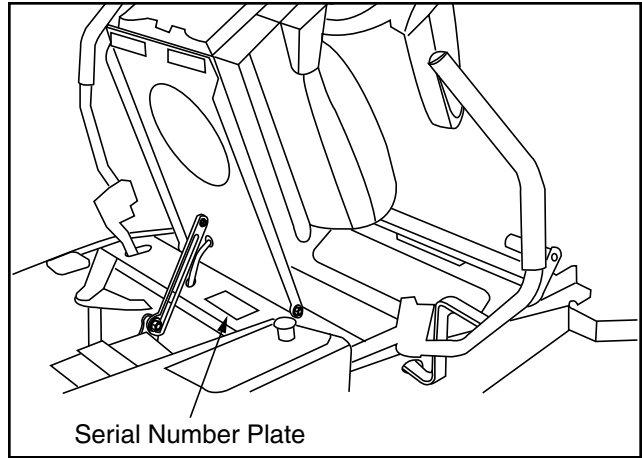

MOWER MODEL

ENGINE MODEL NUMBER

MOWER SERIAL NUMBER

ENGINE SERIAL NUMBER

This is what the mower serial number plate looks like.

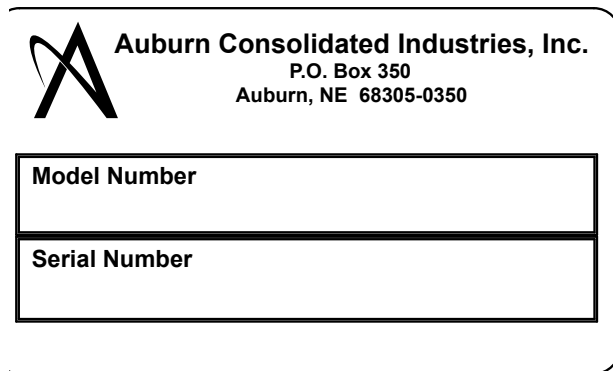

The mower serial number plate is located below the operator's seat on the right hand side of vertical floor panel. Information contained in this serial tag is the model number and the serial number.

The engine model number is found on a decal on the left side of the engine block on the oil reservoir next to the electric starter. The engine serial number is located at the bottom of the same decal.

NOTE: Reference to left-hand and right-hand, used throughout this manual, refers to the position when seated in operator's seat and facing forward.

Engine troubleshooting, repair or adjustments are not covered in this manual. A service manual for the engine can be ordered from a Kawasaki dealer.

INSTRUMENTS AND CONTROLS

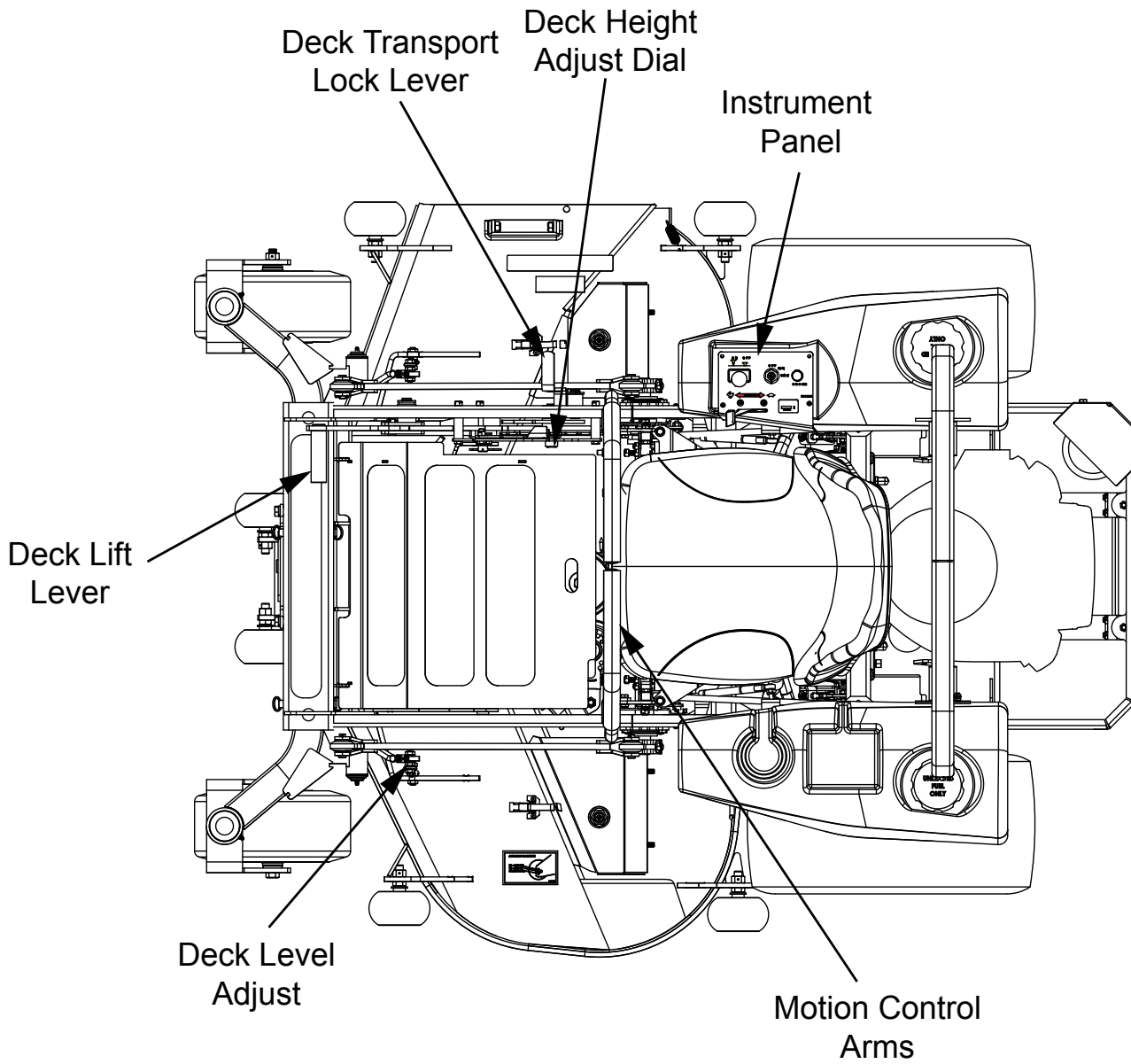

INSTRUMENT PANEL

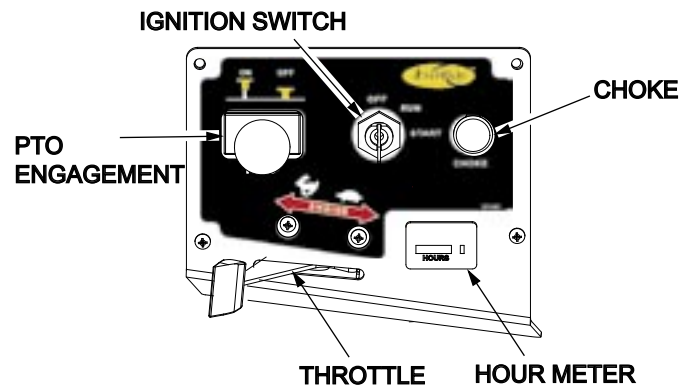

ELECTRIC FUEL SHUT OFF

Turning the ignition switch to the “OFF” position will stop the engine.

IGNITION SWITCH

The Ignition switch has three positions.

OFF - Engine and all electrical circuits off.

ON - Power supplied to all circuits. Normal operating position.

START - Starter activated. This position spring-loaded to “ON”.

ENGINE THROTTLE

⚠ CAUTION: Always control ground speed to insure safe operation. Reduce speed prior to turning or backing the mower.

IMPORTANT: DO NOT “race” or excessively load a cold engine.

The engine throttle controls the engine speed of the unit. Engine speed increases as the throttle lever is moved forward. Decreased engine speed is achieved by moving the throttle lever rearward.

CHOKE

When starting a “cold” engine, it may be necessary to engage the choke by pulling it up. After starting the engine, push the choke closed to keep the engine running smoothly.

16 - INSTRUMENTS AND CONTROLS

PTO ENGAGEMENT

The PTO (Power Take Off) engagement switch will be used to activate the mower for use. When the switch is in the up "ON" position, the mower deck will be engaged. When the PTO switch is down, the PTO is disengaged.

IMPORTANT: When engaging the PTO, always engage it while the engine is at full throttle.

HRMETER

The hour meter keeps track of how many hours the power unit has been in operation.

The hour meter works electronically and is activated as soon as the ignition key is turned to the "ON" position.

COMFORT ADJUSTMENTS



CAUTION: The seat is designed for only one person. Do not allow any passengers to ride on this machine.



CAUTION: Never make seat or steering adjustments while the mower is in motion. Make sure all adjustments are locked prior to operating unit.

The seat moves fore and aft. A cushion spring adjustment knob is also included on the seat. This adjusts to the weight of the operator. For a heavier operator, move the knob clockwise. For a lighter operator adjust the knob counterclockwise.

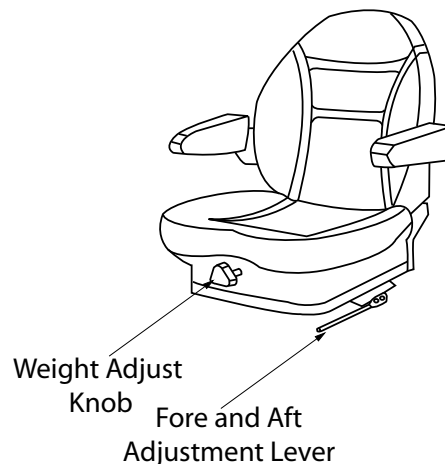

When adjusting the seat fore and aft, make sure the seat is where it is most comfortable to operate the deck raise and lower foot lever.

Both seats are hinged and are capable of being tipped forward for access to the power unit components underneath.

BREAK-IN PERIOD

- Operation of the mower within the first fifty hours can be a major factor in determining the performance and life of the engine and power unit.
- The engine may be operated at full RPM, but excessive load should be avoided. If engine begins to “bog down”, operate the power unit and mower at a slower ground speed while maintaining the engine speed.
- Check engine, pumps, and motors frequently during break-in period. Watch for evidence of leakage of fluids. Replenish levels as required and repair any leaks that may have formed.
- Tighten any nuts, bolts or screws that may have loosened and tighten them as necessary. This is especially true of the wheel retaining nuts.
- Be observant to control arm and parking brake adjustment. Lining materials used on the parking brake will “bed in” in the first few hours of operation and may necessitate the need for early and frequent readjustment.
- Keep area around the fuel tank filler cleaned and make sure the gasoline is of correct octane and free of contamination.
- Initial oil and oil filter change is after the first 8 hours of use and every 100 hours after.



CAUTION: Proper maintenance practices cannot be overemphasized. They are required for safe operation. Consult the “Lubrication and Maintenance” section of this manual for full details.

MOUNTING AND DISMOUNTING SAFELY

DO NOT step on either side of the mower deck when mounting or dismounting the power unit. Step over the deck when mounting or dismounting.

FUEL

Make sure the fuel tank is full, but do not overfill. Gas should remain one inch below the neck of the tank. Be sure to use unleaded gasoline with an octane rating of 87 or higher. The octane rating of a gasoline is a measure of its resistance to knocking. You may use gasoline with up to 10% ethanol by volume.

NOTE: If knocking or pinging occurs, switch to a different brand or a higher octane gasoline.

Make sure dirt and foreign matter is kept out of the fuel tank. Use only a clean funnel and fuel can to fill the tanks.

STARTING THE EVERRIDE MOWER

Pre Start Inspection

Prior to daily start-up of the mower, a few basic procedures should be followed to insure the machine is in optimal operating condition.

- Make sure all safety shields are in place and secured properly.
- Make sure the operator is instructed on correct and safe operation of the power unit and related attachments and implements.
- Check engine and hydraulic reservoir oil and replenish as necessary.
- Check the pump belt and drive belt tension and adjust as necessary.
- Insure air intake screens are clear of debris to provide maximum engine cooling.
- General inspection of tires, tire pressure and wheel bolt torque. Observe for external signs of leakage and correct before operating the mower. Check motion control arms for looseness and correct position.

18 - OPERATING THE POWER UNIT

- Check for adequate fuel supply. It is recommended that the fuel tank be replenished following each days use to reduce condensation and provide a full tank for next use.

 **WARNING:** Carefully read and understand the **SAFETY** section of this manual.

 **WARNING:** Always start and operate the engine in a well ventilated area. If in an enclosed area, vent the exhaust outside.

 **WARNING:** Do not modify or tamper with the exhaust system.

Normal Starting

 **CAUTION:** Do not attempt to start the engine unless you are seated in the operator's seat. Do not allow anyone on the mower except the operator.

Sit on the operator's seat. Be sure the handles are both facing out in the park position and the PTO is not engaged.

The choke control knob is located on the control panel. To start a cold engine, pull the choke control up to the on position. After the engine starts, move the choke control down toward the "OFF" position, keeping enough choke to keep the engine running smoothly.

NOTE: Be sure the choke is in the "off" position during normal engine operation. Running with the choke in the "On" position can cause damage to the engine.

Use the throttle control lever to increase and decrease the engine speed. Moving the lever forward will increase the engine speed while moving the throttle backwards will lower the engine speed. When starting the power unit, set the throttle at half speed.

Insert the key into the ignition switch and turn to the right to the start position and then release the key after the engine has started.

NOTE: Because of safety features, the engine can't be started unless the control arms are in the park position, the operator is in the seat, and the mower PTO is off.

Allow the engine to idle for a few minutes before increasing the throttle or engaging the PTO.

Before turning off engine disengage the PTO, put the handles in neutral, and pull the throttle back to a low idle. Allow the engine to idle for a few minutes and then turn the engine off by turning the key left to the off position. Be sure to remove the key before getting out of the operator's seat.

IMPORTANT: DO NOT leave the key in the ignition while the machine is unattended.

Do not operate the engine starter for more than thirty seconds at a time. An interval of at least two minutes should be allowed between cranking periods to prevent the starter from overheating or burning out.

Starting In Cold Weather

When the temperature is below -5°C (23°F) and the engine is cold do not try to start the engine for more than ten seconds at a time. If the engine does not start after 10 seconds, turn the ignition to "OFF" and let the mower stand for 30 seconds. To protect the battery and the starter, make sure the starter does not turn for more than 10 seconds continuously.

Jump Starting The Power Unit

 **WARNING:** Battery gases can be explosive. Keep all cigarettes, sparks or flames away from the battery.

 **WARNING:** If the battery is frozen, do not attempt to jump start the engine.

⚠ WARNING: Do not connect the negative battery cable to the power unit battery.

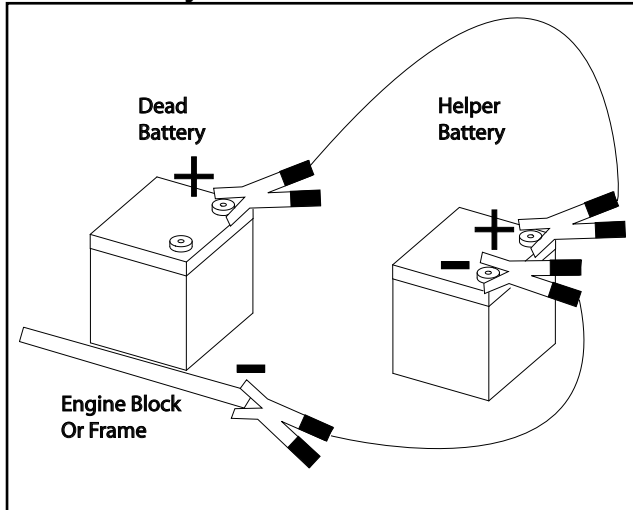

IMPORTANT: This mower has a 12-volt negative ground starting system. Use only helper vehicles with the same voltage. Use of a higher electrical voltage vehicle to jump this machine could result in damage to the electrical system.

1. Pull the helper vehicle close enough for easy connection to the battery.

⚠ WARNING: Do not allow the vehicles to touch when attempting a jump start.

2. Put the mower motion control arms in the park position and put the helper vehicle in the neutral position and apply the parking brake. Turn the engine off.
3. Put on safety goggles and rubber gloves.
4. Attach the red clamp to the red pole (positive +) on the dead mower battery. Attach the other red cable to the red pole (positive +) on the helper vehicle.
5. Attach the other black cable to the black (negative -) pole on the helper vehicle.

6. Connect the black cable to the mower frame or engine block for a ground. Connect this as far from the mower battery as possible.
7. Start the helper vehicle and let it run for a short amount of time. Start the disabled mower.
8. Disconnect the cables in the exact reverse order. Start with step 6, then 5 and 4.

WARMING THE MOWER

⚠ CAUTION: To avoid personal injury, make sure the control arms remain in the park position during warm-up.

Allow the engine to idle for five minutes after start-up. This allows oil to reach all working parts. Failure to allow the machine to warm-up before applying a load could cause premature wear, seizure, or breakage.

In cold weather the viscosity of hydraulic oil may increase. This can cause decreased oil circulation and low oil pressure. Using the power unit before properly warmed up could cause damage to the hydraulic system. For the proper warm-up time, see the chart below.

| TEMPERATURE | WARM-UP TIME REQ. |
|---------------------------|----------------------|
| Higher than 0°C (32°F) | 5 Minutes |
| 0 to -10°C (14-32°F) | 5-10 Minutes |
| -10 to -20°C (14 to -4°F) | 15 Minutes |
| Below -20°C (-4°F) | More than 15 Minutes |

INCREASING ACCELERATION

Moving the throttle lever forward increases the engine speed and moving it backwards will decrease the engine speed.

For good mowing performance it is important to run the engine at a high speed, but drive at a steady ground speed. If streaking or trailing occurs, decrease your ground speed.

20 - OPERATING THE POWER UNIT

LOCKING THE FRONT AXLE

The mower is shipped with the front axle in the floating position. To lock the front axle so it can't float, remove the two 5/8 x 5 pins from the locations shown and insert them into the outer hole locations on the frame as shown.

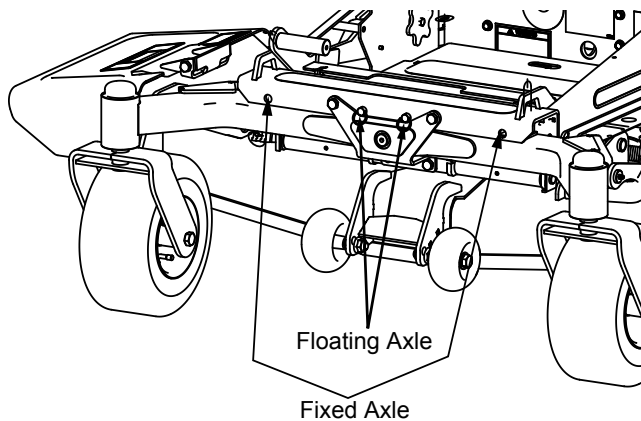

RAISING THE MOWER DECK

⚠ DANGER: Before raising the deck to the transport position, insure the PTO is disengaged and the motion control arms are in the park position.

Place your right foot on the deck lift lever and press it until the deck is locked in the transport position.

To lower the deck, push the deck lift lever in with your right foot and pull the deck lock lever back. Slowly lower the deck back to mowing position. Release the deck lock lever.

OPERATING THE EVERRIDE MOWER

Before using the mower to mow for the first time, it is beneficial to operate the EverRide mower at low speeds in an open area to acclimate yourself to the machine controls.

The control arms are located on both sides of the operator's seat. These arms are used to control the forward, reverse and turning motion of the

power unit. See the following section for an explanation of the steering controls.

STEERING CONTROLS

After starting the power unit, pull the motion control steering levers back together out of the lock position and into the neutral position. You are able to steer the power unit using the motion control levers.

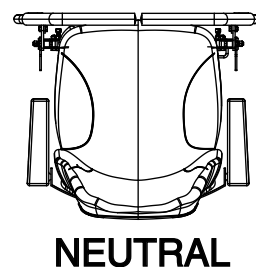

To go forward, push both levers straight ahead.

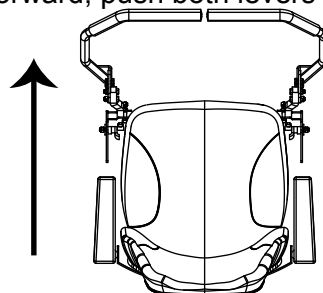

To go in reverse, pull both levers straight back.

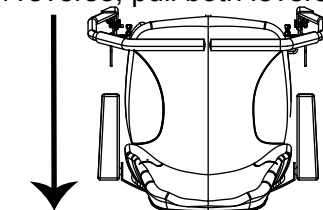

To turn right in reverse, leave the right lever in neutral and pull back on the left lever.

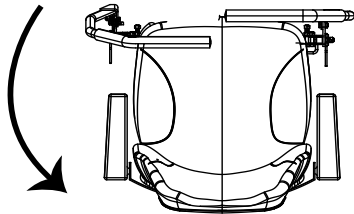

REVERSE LEFT

To turn left in reverse, leave the left lever in neutral and pull the right lever straight back.

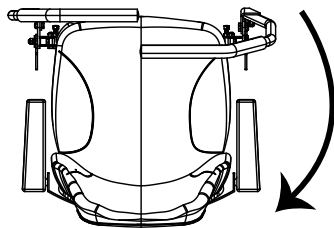

REVERSE RIGHT

To turn right, leave the right lever in neutral and push the left lever straight ahead.

To make a sharp right turn, push the left lever straight ahead and pull the right lever straight back.

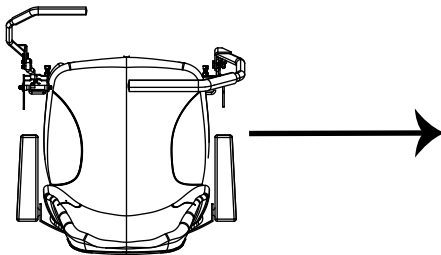

SHARP RIGHT

To turn left, leave the left lever in neutral and push the right lever straight ahead.

To make a sharp left turn, push your right lever straight ahead and pull straight back on the left lever.

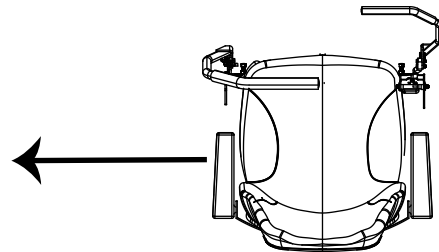

SHARP LEFT



CAUTION: Use caution when making turns. Slow the machine down to a manageable speed before making sharp turns. This mower can spin very rapidly when pushing forward on one lever and pulling back on the other.

STOPPING THE ENGINE

Move the control arms to the park position, idle the engine a few moments and turn the ignition switch to the "Off" position. Remove the key.

MOVING A STALLED EVERRIDE MOWER

If the mower engine stalls and will not restart the unit can be pushed or towed for short distances with the pump bypass valves open. Do not exceed 5 m.p.h. when towing.

IMPORTANT: The bypass valves must be opened two full turns before the unit is moved. Be sure the bypass valves are returned to their original closed position before running the mower again. Failure to fully close the bypass valves before operation could result in hydraulic system damage.

TOWING WITH AN EVERRIDE MOWER

The EverRide mower is designed for pulling in light duty applications only. Never attempt to pull more than 250 lbs. (113.6 kg).



WARNING: Exercise care when turning the EverRide mower while towing. The EverRide mower will turn more sharply than the towed object.

22 - OPERATING THE POWER UNIT

IMPORTANT: Attempting to pull more than 200 pounds (113.6 kg) with the EverRide mower will lead to premature parts failure that will not be covered under warranty.

IMPORTANT: Failure to close bypass valve completely before operation can result in hydraulic pump damage.

PARKING THE POWER UNIT



CAUTION: When parking the EverRide mower, stop the engine, lower the mower to the ground, move the motion control arms to the park position, turn the key to the “OFF” position and remove the key.

When parking on an incline, be sure to chock the wheels on the downhill side to prevent the power unit from rolling.

LOADING THE MOWER



WARNING: Exercise extreme caution when loading and unloading the unit from a ramp.



WARNING: Use only a single, full width ramp. If individual ramps are necessary, use several to simulate a single full width ramp. Use enough ramps to create an unbroken ramp surface wider than the unit.



WARNING: Never exceed a 15 degree angle between the ramps and the truck or trailer when loading the mower.



WARNING: Avoid sudden acceleration and deceleration of the unit when loading and unloading the unit to avoid the mower from tipping backward.

The ramp should be long enough that the angles between the truck or trailer do not exceed 15 degrees. A steeper angle may cause the mower deck components to get hung up when moving

the mower from ramp to truck or trailer. If loading on or near a slope, position the truck or trailer on the down side of the slope and the ramps should extend up the slope. This will minimize the ramp angle. The trailer or truck should be parked as level as possible to facilitate smooth loading of the mower.

TRANSPORTING THE MOWER

Use a heavy duty trailer or truck to transport the mower. Insure the trailer or truck has all of the necessary lighting and markings as required by law.

When transporting the mower, make sure the motion control arms are in the park position, the wheels have been blocked, the machine has been securely fastened by cables, chains or ropes, and the trailer has been secured to the towing vehicle with safety chains.



WARNING: Driving on a public street or roadway without turn signals, slow moving vehicle emblem, or reflective markings could lead to accidents causing serious personal injury or death. Do not drive the mower on a public street or roadway.

GENERAL INFORMATION

The safe operation of the power unit and mower deck is the responsibility of the operator. The operator **MUST** be familiar with the mower and power unit controls, how they work, and all safety precautions **BEFORE** starting operation.

IMPORTANT: To avoid damage to the mower, re-torque all fastening hardware, including blade and spindle pulley retaining nuts, after the first hour of mowing operation.



CAUTION: Inspect the mowing blade bolts daily, or whenever a blade has been removed. Torque is 110 to 130 Ft. Lbs. (150-177 N•m).

OPERATING SIDE DISCHARGE MOWERS

The mower has a hinged discharge shield that discharges the clippings out of the side of the deck and onto the ground.



DANGER: Without the discharge shield or a complete grass collector installed, you and others are exposed to rotating mower blades and thrown debris. Contact with the mower blades or flying debris could cause severe injury or death.



DANGER: Never remove the discharge shield from the mower because the deflector routes discharged material down toward the ground. If the discharge shield is ever damaged, do not use the mower until it has been replaced.



DANGER: Never put your hands or feet under the mower.



DANGER: Do not try to clear the mower discharge area or mower blades without first turning the mower PTO to off, turning the ignition key to off, removing the key and disconnecting the battery cable.

TIPS FOR EFFICIENT MOWING

Blade sharpness affects the appearance of the mowed lawn. A dull or damaged blade will cause grass to appear torn or beaten off, rather than cut cleanly. Mowing blades should be checked regularly and kept sharp to insure the best lawn appearance.

Best results occur normally when the grass is maintained at a height of 2-3 inches (50mm-80mm). It is best to cut the grass often and not too short. To keep a healthy green lawn, do not cut more than 1/3 of the overall grass blade height.

Mower engine speed while mowing should be at the maximum rated RPM. This will insure proper blade speed for effective cutting and discharge of grass clippings.

Travel speed greatly affects mowing performance. The operator must use his or her own best judgment for the ground speed required for encountered mowing conditions. Always use a lower ground speed for slower mowing, rather than lowering the engine RPM.

Mow often! Do not wait for the grass to get too tall. Short grass clippings will disperse better and deteriorate faster.



CAUTION: Clear the area of people, pets, and all visible debris before beginning mowing operations.

Mowing areas with tall grass or weeds may require cutting at 6 inches (maximum) height of cut. After mowing once, recut the entire area with the mower reset to the desired final height of cut.

24 - OPERATING THE MOWER

When cutting along sidewalks, driveways, etc., it is advisable to mow with the discharge directed away from them for 2 or 3 passes. This will keep the grass clippings off of this area.

⚠ WARNING: Always keep the mower discharge directed away from people or animals which could be injured, or away from objects which could be damaged by debris thrown by the mowing blades.

The caster wheels on either side of the front of the mowing deck serve as a convenient mowing guide. When mowing, position the mower so the wheel overlaps the edge of the strip previously cut. This will assure full mowing coverage.

Always keep the left side of the mower toward trees, posts or any other obstacles on the first trip around them.

⚠ CAUTION: Mow only during daylight hours, or when the area is well lit artificially.

When transporting, always disengage the mower PTO.

⚠ WARNING: To avoid injury from flying debris, never operate the mower in the raised transport position.

CUTTING HEIGHTS:

The mower can be adjusted to mow from 1 inch to 6 inches (25 - 152 mm) height of cut. Grass mowing height should be determined by encountered conditions and personal preferences.

The following recommendations are provided as a guide for cutting height selection.

Lawns = 1" to 3" (38-76 mm)
Field Cutting = 3" to 6" (76-152 mm)

ADJUSTING MOWER HEIGHT OF CUT

Raise the mower deck by pressing the foot arm weldment until it locks into the transport lock position. Rotate the cam control weldment so the desired height of cut is shown. Lower the deck to the cut position out of the transport lock position by pressing the foot arm weldment and pulling back on the transport lock handle.

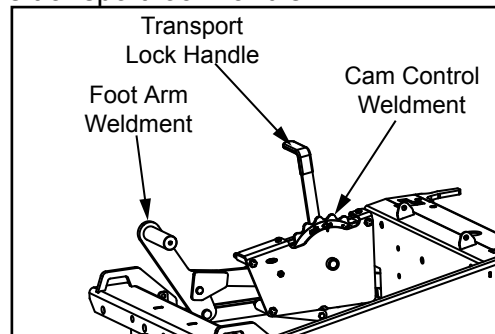

GAUGE WHEEL ADJUSTMENT

1. Raise the mower by pushing down on the deck raise lever and lock into transport position.
2. Place the motion control arms in the park position.
3. After determining the desired height of cut, raise the lift lock lever and rotate the height of cut handle until cam control weldment is in the correct cut height location. Make sure the lock lever is inserted back into the appropriate notch in the wheel.
4. Set the anti-scalp adjustment to coincide with the height of cut which was chosen. To adjust the anti-scalp rollers, remove the 1/2-13 x 5 bolts and reinstall the bolts back in the appropriate hole for the desired height of cut. See illustration on page 25 for correct hole information.

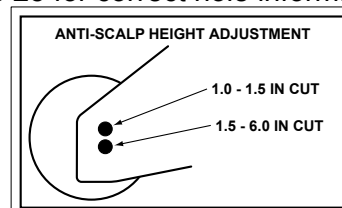

5. Depress the deck raise lever and pull back on the transport lock lever and lower the deck back into the cut position.

The anti-scalp wheels should always be at least 1/4" - 1/2" (6mm - 13mm) off of the ground. They are meant to keep the deck from scalping the ground in uneven terrain, they are not meant to run along the ground all of the time.

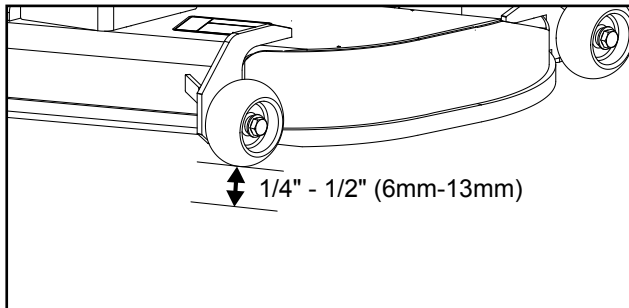

UNEVEN TERRAIN

Pre-plan mowing over uneven terrain so the grass will be dry, minimizing wheel slippage and spinning, which will damage the turf.

- WARNING:** To avoid the loss of control and to prevent overturning the mower, always across slopes, never up and down.

Pass diagonally through sharp dips. Avoid sharp drop offs completely to prevent "hanging up" the mower.

- CAUTION:** Keep the power unit motion control arms forward when going downhill.

Before mowing, check the area to determine the best procedure. Consider the grass type and height, and the type of uneven terrain on which the mowing is to take place.

Avoid sudden starts and stops while traveling up or down hill, and slow the ground speed while turning.

GRASS DISCHARGE

The mower deck has been designed to provide maximum air flow for an even discharge of grass clippings. When mowing tall, or lush grasses, select a lower mower ground speed, or reduce the width of cut, for the best discharge efficiency.

- WARNING:** Never operate the mower with the discharge shield in the raised position.

For the best lawn appearance, do not mow when the grass is wet or heavy with dew. Wet grass could plug the discharge area of the mower, creating an unnatural load through the blades and spindles, possibly damaging the mower deck belt. Wet grass will also leave unsightly clumps on the lawn.

If the mower deck should become clogged, back the unit out of the uncut grass. If the mower will not clear itself, raise the deck, shut off the engine, set the brake, remove the ignition key and clean the bottom of the deck.

- WARNING:** The operator should never attempt to leave the mower seat, with the mower blades rotating, with the mower in motion, or when the engine is running.

In medium and heavy cutting conditions, mow so the discharged clippings will be AWAY from the uncut grass. In light cutting, discharged clippings can be directed onto the uncut grass, allowing them to be recut finer, leaving the lawn almost free of unsightly clippings.

26 - PARTS

PARTS

Use only genuine **EverRide** service parts. Off the shelf (after market) repair parts may compromise the integrity of the unit. Parts that do not meet **EverRide** specifications may fail, causing injury, equipment or property damage.

Our part numbers can change. When ordering, use the part numbers listed below. If the numbers do change, your **EverRide** dealer will have the correct numbers.

When ordering, make sure to have your power unit and engine serial numbers readily available. You should have recorded these numbers on the identification section of this manual.

Common Mower Parts

| Item | Part No. |
|----------------------------------|----------|
| Belt, Deck - 54" | 181036 |
| Belt, Deck - 60" | 112616 |
| Belt, Deck - 60" | 181711 |
| Blades, Mower - 54" Deck | 181042 |
| Blades, Mower - 60" Deck | 181026 |
| Blades, Mower - 66" Deck | 181707 |
| Discharge Shield | 181173 |
| Shield, LH Deck Belt - 54" | 180778 |
| Shield, LH Deck Belt - 60" | 180496 |
| Shield, LH Deck Belt - 66" | 181708 |
| Shield, RH Deck Belt - 54"-60" | 180494 |
| Shield, RH Deck Belt - 66" | 181709 |
| Spindle Assembly - Center | 181910 |
| Spindle Assembly - Outer | 181917 |
| Spindle Bearing Kit | 180925 |
| Spring, Extension - Deck Tension | 104657 |
| Wheel, Gauge - 5.0" | 162701 |

Common Tractor Parts

| Item | Part No. |
|--|----------|
| Air Filter, Primary - Kohler/Kawasaki | 181071 |
| Air Filter, Secondary - Kohler/Kawasaki | 181072 |
| Air Filter, Briggs & Stratton | 191630 |
| Pre-Cleaner, Briggs & Stratton | 191632 |
| Belt, Clutch To Deck | 181715 |
| Belt, Hyd. Pump Drive | 181727 |
| Belt, Hyd. Pump Drive - ZBR2660, ZGC5460, ZKH2766 | 181882 |
| Cable, Choke - Kawasaki/B&S | 180273 |
| Cable, Choke - Kohler 27 H.P. | 181143 |
| Cable, Throttle | 181296 |
| Dampener, Steering Control | 180231 |
| Engine Oil Filter - Kawasaki 25 H.P. | 181073 |
| Engine Oil Filter - B & S 26 H.P. | 191631 |
| Engine Oil Filter - Kohler 27 H.P. | 191190 |
| Fuel Filter | 181060 |
| Fuel Tank Cap | 181251 |
| Hydraulic Oil Filter | 180909 |
| Hydraulic Oil Reservoir Cap | 181210 |
| Key, Ignition | 105684 |
| Pump Cooler Fan | 180993 |
| Solenoid, Starter | 180640 |
| Switch, Ignition | 180620 |
| Switch, PTO Engagement | 136574 |

LUBRICATION AND PERIODIC MAINTENANCE

SPECIFICATIONS AND CAPACITIES

Engine Oil

Use the appropriate SAE viscosity. Oil must meet or exceed; API Service "SF", "SG", "SH", or "SJ" requirements.

Capacity (Crankcase and Filter)..... 1.9 U.S. qts. (1.8 L) - 25 H.P. Kawasaki
 2.0 U.S. qts. (1.9 L) - 27 H.P. Kohler
 2.0 U.S. qts. (1.9 L) - 26 H.P. Briggs and Stratton

Recommended Viscosity:

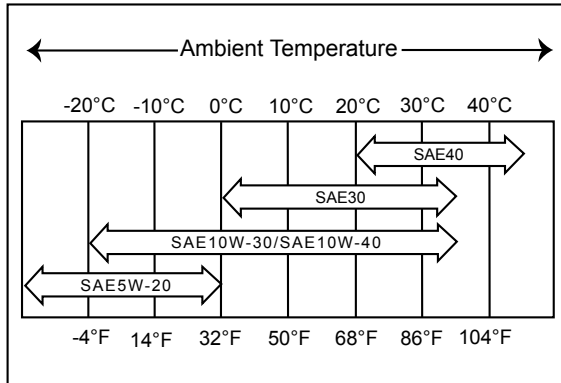

25 H.P. Kawasaki

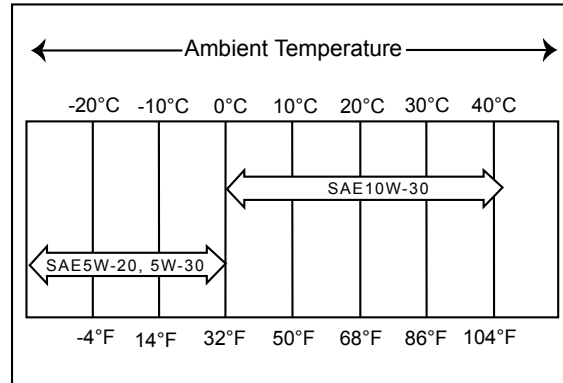

27 H.P. Kohler

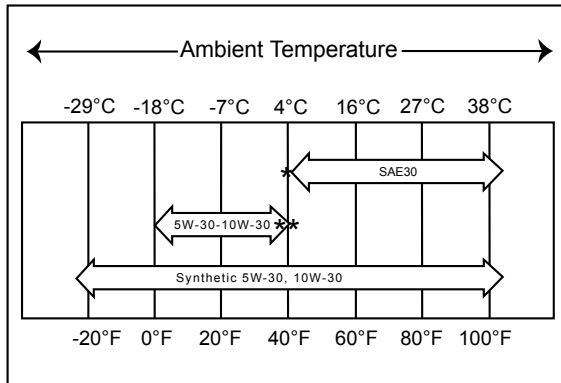

26 H.P. Briggs & Stratton

* Air cooled engines run hotter than automotive engines. The use of non-synthetic multi-viscosity oils (5W-30, 10W-30, etc.) in temperatures above 40° F (4° C) will result in higher than normal oil consumption. When using a multi-viscosity oil, check oil level more frequently.

** SAE30 oil, if used below 40° F (4° C) will result in hard starting and possible engine bore damage due to inadequate lubrication.

Recommended Change Interval

Initial Oil and Filter Change..... 8 hours

Oil and Filter Change, Thereafter..... Every 100 hours

28 - LUBRICATION AND MAINTENANCE

Fuel Tank

| | |
|-----------------------|--------------------------------|
| Capacity..... | 11.83 U.S. gals. (44.8 liters) |
| Fuel Recommended..... | Unleaded 87 Octane or Greater |

Hydraulic System

| | |
|--|---------------------|
| Capacity..... | 1 gal. (3.8 liters) |
| Recommended Oil Viscosity..... | SAE 20W-50 |
| Initial Hydraulic Oil and Filter Change..... | 50 hours |
| Hydraulic Oil and Filter Change, Thereafter..... | 250 |

Grease Fittings

NOTE: To insure the spindle cavity is completely full, grease should vent out of the top seal.

| | |
|-------------------------------------|---|
| Grease Interval (All fittings)..... | See Chart Below |
| Recommended Grease..... | Lithium Complex with drop point exceeding NLGI #2 to meet or exceed GC specs as defined by ASTM D4950 |

NOTE: Change intervals stated above are for normal usage. Due to adverse operating conditions that may be experienced (extremely dusty or muddy), change intervals may need to be more frequent.

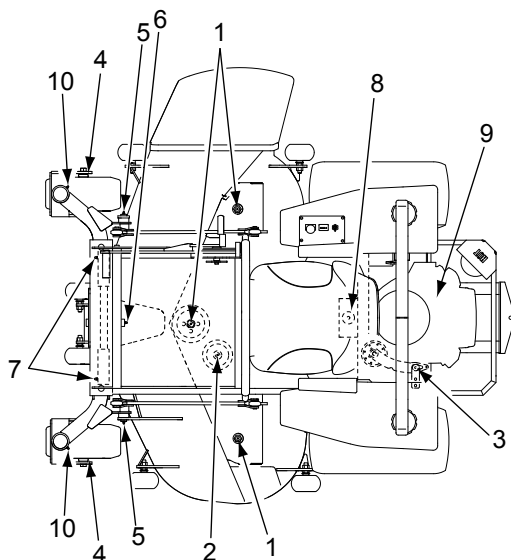

LUBRICATION INTERVALS

| REF | DESCRIPTION | FREQUENCY |
|-----|------------------------|-----------|
| 1 | BLADE SPINDLES (3) | 25 HOURS |
| 2 | DECK PIVOT IDLER (1) | 25 HOURS |
| 3 | PUMP DRIVE TENSION (1) | 25 HOURS |
| 4 | FRONT WHEEL AXLES (2) | 40 HOURS |
| 5 | LIFT LINK PIVOTS (2) | 40 HOURS |
| 6 | FRONT AXLE PIVOT (1) | 40 HOURS |
| 7 | DRAG LINK PIVOTS (2) | 40 HOURS |
| 8 | HYDRAULIC FLUID LEVEL | DAILY |
| 9 | ENGINE OIL LEVEL | DAILY |
| 10 | WHEEL FORK PIVOTS (2) | YEARLY |

PERIODIC MAINTENANCE SCHEDULE

Recommended Interval, Each:

| Day | 50 hr | 100 hr | 250 hr | Item To Check | Action Required |
|-----|-------|--------|--------|-------------------------------|---------------------------|
| . | | | | All controls, switches | Inspect and repair |
| . | | | | All fasteners, hardware | Check and tighten |
| . | | | | Hoses, fan belt, wiring | Inspect and repair |
| . | . | | | Grease fittings | Lubricate |
| . | | | | Engine oil level | Check and replenish |
| (*) | | . | | Engine oil and filter | Replace |
| . | | | | Hydraulic oil level | Check and replenish |
| | (*) | | . | Hydraulic oil & filter | Replace |
| . | | | | Air screens | Clean off debris |
| . | | | | Air cleaner dust ejector | Clean |
| [.] | | | . | Air cleaner elements | Inspect, clean or replace |
| . | | | | Fuel tank level | Refill to full level |
| . | | | | Fuel filter sediment bowl | Inspect and clean |
| | | . | | Fuel filter element | Replace |
| | . | | | Battery electrolyte level | Check and replenish |
| . | | | | Brake adjustment & balance | Check and adjust |
| . | | | | Tire pressure & condition | Check and adjust |
| . | | | | Wheel bolt torque | Check and tighten |
| . | | | | Steering free-play | Check and repair |
| . | | | | Check safety shut off system | Check and repair |
| . | | | | Clean grass buildup from deck | Clean |
| . | | | | Inspect mower blades | Check, sharpen or replace |
| . | | | | Check for loose hardware | Replace or re-torque |
| . | | | | Inspect belts | Tension or replace |
| | | | . | Inspect hydro hoses | Inspect and repair |

Items marked (*) indicate initial service interval only. Subsequent (later) intervals marked “.”. Intervals above are for normal usage. Items marked [.] should be cleaned and inspected every 25 hours. Severe operating conditions (wet, dusty, etc.), or when previous servicing has indicated need for more frequent action, intervals may need to be more often.

AVOID FUMES

- ⚠ CAUTION:** Engine exhaust fumes contain carbon monoxide and can cause serious illness or death.
- ⚠ CAUTION:** Never run the mower's engine inside an enclosed area. Operate it only outside or in a location with proper ventilation.

SERVICE ACCESS

- ⚠ CAUTION:** Shut off the engine before servicing the mower.
- ⚠ CAUTION:** Make sure the seat is fully raised and locked before performing any maintenance on the mower.
- ⚠ CAUTION:** The seat can come down very quickly once the seat lock lever is released. Lower the seat slowly making sure to pay close attention that everything is clear.

To access the battery and the hydraulic reservoir it is necessary to raise the seat of the power unit. Use caution while lifting and insure the seat is locked in the upright position before beginning service on the mower.

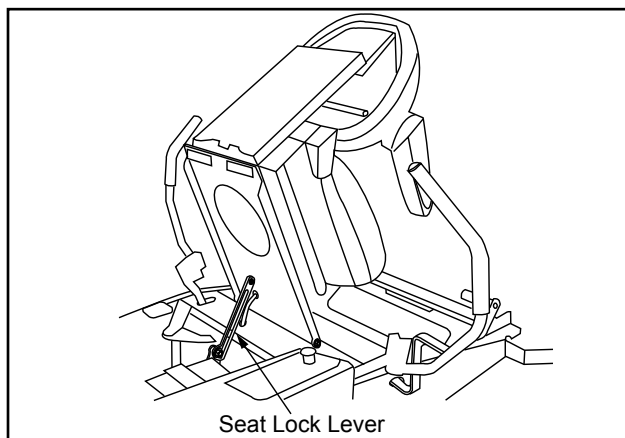

To lower the seat back down, push forward on the seat slightly and pull the lift lever rearward out of the lock position. Lower the seat slowly back into contact with the frame.

ENGINE OIL LEVEL

IMPORTANT: Failure to check the engine oil level regularly could lead to serious engine problems if oil is too low.

The mower must be parked on level ground with the engine off. Clean the area around the dipstick before removing it. Remove the dipstick and check that the oil level is between the upper limit and the lower limit on the dipstick. Wipe off dipstick, momentarily reinstall in engine (WITHOUT TURNING IT) and check oil level again. Add oil as necessary to achieve the desired level. **DO NOT OVERFILL.** Reinstall and tighten the dipstick.

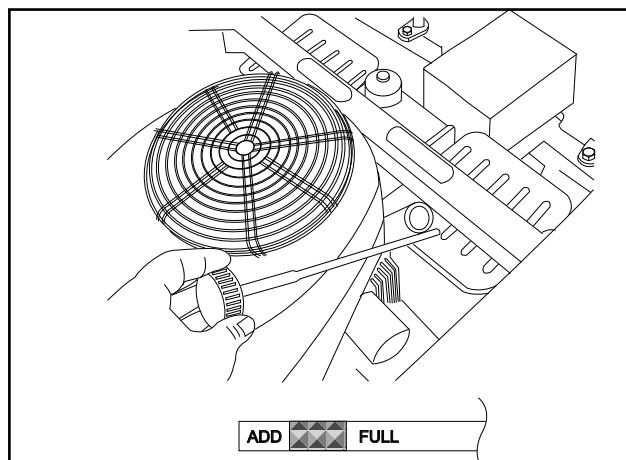

IMPORTANT: Use caution to prevent from overfilling the engine with oil.

IMPORTANT: Use only the oil specified for use in the engine owner's manual.

CHANGING THE ENGINE OIL

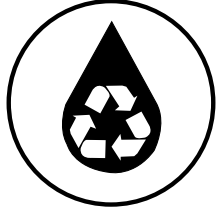

⚠ WARNING: Engine oil is a toxic substance. Dispose of used oil properly. Contact your local authorities for approved disposal methods or possible recycling.

Change the engine oil after 8 hours of operation. Change the oil each subsequent 100 hours of operation after the initial change.

1. Run the engine to warm the oil.
2. Park the mower on level ground.
3. Stop the engine, put the motion control arms in the park position and remove the key.
4. Remove the oil drain screw and drain the oil into a suitable container while the engine is still warm.

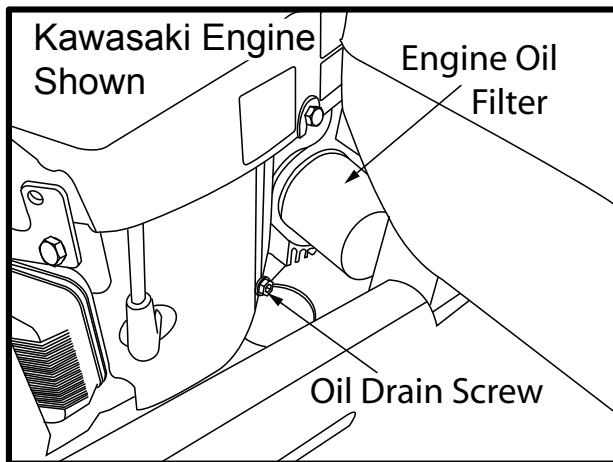

⚠ WARNING: Hot engine oil can cause severe burns. Allow engine oil temperature to drop from hot to warm before attempting to drain and handle the oil.

5. Install the oil drain screw.
6. Remove the dipstick and refill with fresh oil.
7. Check the oil level.

OIL FILTER CHANGE

Change the engine oil filter initially after the first 8 hours of use. Change the engine oil filter every 100 hours of operation after the initial change.

1. Drain the engine oil into a suitable container.

⚠ CAUTION: Before removing the oil filter, place a suitable pan under the filter connection.

2. Clean the area around the oil filter to keep dirt and debris from the engine and rotate the oil filter counterclockwise to remove it. Wipe off the surface where the filter mounts.
3. Coat a film of clean engine oil on the seal of the new filter.

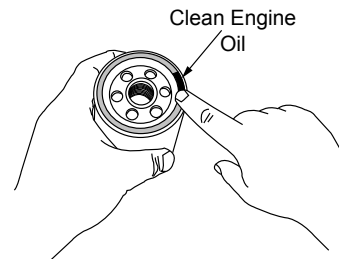

4. Install a new filter rotating it clockwise until the seal contacts the mounting surface. Rotate the filter 3/4 of a turn more by hand.
5. Refill with engine oil as specified.
6. Run the engine for about 3 minutes, stop engine, and check for leakage around filter.

HYDROSTATIC MAINTENANCE

 **CAUTION:** Avoid damage to the hydraulic components as a result of contamination. Be sure to wipe around the filler neck and cap before removal of the hydraulic oil reservoir cap. Do not open the oil reservoir cap unless it is absolutely necessary.

Check the reservoir daily for the proper fluid level.

The pump and motor units require fluid changes yearly or every 250 hours whichever occurs first. The system filter should be changed initially after the first 50 hours of break in. The fluid and filter should be changed and the system cleaned if the fluid would become contaminated with dirt, water, etc.

NOTE: The integrated pump/motor units are equipped with bypass valves. Please note information in the operation section in relation to moving a stalled power unit.

CHANGING HYDRAULIC FLUID

 **CAUTION:** Be sure the engine has been stopped, the motion control arms are in the park position, and the key has been removed before changing or checking the hydraulic oil in the mower.

 **CAUTION:** Allow the hydraulic fluid an opportunity to cool. The oil may be hot and could cause serious burns.

1. Park the machine on a level surface, stop the engine, put the motion control arms in the park position and remove the key.
2. Clean the area around the reservoir filler cap and remove the filler cap from the reservoir.

3. To drain the hydraulic fluid, place a suitable container under the hydraulic filter and remove it.
4. Place a thin coat of hydraulic oil on the gasket on the oil filter.
5. Install the hydraulic oil filter onto the filter adapter.
6. Refill the hydraulic reservoir to the recommended level. Reinstall the oil reservoir filler cap.
7. Clean up any fluid which may have spilled.

BLEEDING/PURGING THE HYDRAULICS

IMPORTANT: Air in the hydraulic system is the NUMBER ONE cause of hydraulic pump failures. In all cases following hydraulic system service or repair, the hydraulic system MUST be correctly purged of trapped air before placing the zero-turn mower back in operation.

1. Make sure the oil tank is full, the oil must barely cover the fill baffle inside of the tank.
 2. Raise the rear unit tires off the floor and place it on suitable jack stands.
 3. Open both pump bypass valves, one on each pump, two full turns.
 4. Sitting in the operator's seat, start the engine and run it at idle.
 5. Slowly cycle the motion control arms full forward and full reverse for 10 seconds in each direction, 5 or 6 times. This allows no load oil flow between the pumps and wheel motors.
- NOTE:** The rear tires should rotate, but they'll not be under load.
6. Shut off the engine, check and add hydraulic oil as necessary.

7. Close the bypass valves on both pumps. Do not over tighten.
8. Sitting in the operator's seat, start the engine and run it at idle.
9. Slowly cycle the motion control arms full forward and full reverse, 5 or 6 times.

IMPORTANT: The rear tires are now rotating under power. Do not touch or contact them. If they do not rotate after 2-3 cycles, stop immediately. There may still be air in the system. Let the pumps cool and try purging again from the beginning.

10. Shut off the engine, check and add hydraulic oil as necessary and lower the unit back to the floor.

NOTE: It may be necessary to repeat purging procedures until all air is vented out of the hydraulic system.

CHECKING THE HYDRAULIC HOSES

Inspect the hydraulic hoses to insure they are in good working order every 250 hours.

Check both the hoses and hose clamps to insure there is no wear or damage. If either is found worn or damaged, repair or replace them at once.

BATTERY MAINTENANCE



WARNING: Battery posts, terminals and related accessories contain lead and lead components, chemicals known by the state of California to cause cancer and reproductive harm. Wash hands after handling.

The original battery shipped with the mower is either maintenance free and non-accessible or maintainable.

If your battery has vented caps, it will be required to check the electrolyte levels. It is recommended to check the electrolyte levels weekly or every 40 hours, whichever comes first.

Dirt and fluid on the top of the battery can cause it to discharge. Corrosion on the battery posts or battery terminals can cause poor battery performance.

If the battery is weak, the engine will be difficult to start. It is important to check the battery performance periodically.

1. Remove the battery from the machine; Refer to removing the battery on page 34.
2. Clean the top of the battery and remove the vent caps for the battery. Visually inspect the electrolyte levels in the cells. If electrolyte is below the bottom of the vent well, fill with clean distilled water to the bottom of the vent wells (1/4 to 1/2 inch above plates) Reinstall the vent caps.
3. Clean the cable ends and battery posts with steel wool. Use a solution of baking soda and water to clean the battery. Do not allow the solution to enter the battery cells.

IMPORTANT: Electrolytes are very corrosive. Do not fill the battery while it is installed as severe frame corrosion could result.

INSTALLING THE BATTERY

1. Insert the battery (1) in the tray with the battery posts facing to the left.
2. Install the positive battery cable to the positive post on the battery.
3. Install the negative battery cable to the negative post on the battery.
4. Secure the cables by inserting a 5/16-18 x 5/8 carriage bolt through the battery post and through the battery cable. Secure it with a 5/16-18 whiz locknut.

34 - LUBRICATION & MAINTENANCE

5. Install the red terminal boot over both the positive post and the positive cable.
6. Secure the battery in place by inserting one end of the hook band into the battery tray and running the other end over the top of the battery into the slot on the opposite end of the battery tray.
5. Slide the rubber strap out from the battery tray. Carefully release the strap and slide the opposite end out of the hooks on the battery trays.
6. Carefully remove the battery using caution to avoid touching the terminal posts on any metal parts.

REMOVING THE BATTERY

 **WARNING:** The battery terminals or metal tools could short against the metal components of the mower causing a spark that could ignite explosive battery gases. When removing the battery from the mower, do not allow the battery terminals to touch any part of the machine. Do not allow metal tools to touch metal parts of the machine while in contact with the battery terminals.

 **WARNING:** Incorrect battery cable routing could damage the mower or cause a spark that could result in explosive battery gases being ignited.

 **WARNING:** Always disconnect the black (negative) battery cable before disconnecting the red (positive) battery cable. Always reconnect the red (positive) battery cable first before reconnecting the black (negative) battery cable.

1. Disengage the mower PTO switch, put the motion control arms in the park position, turn the ignition key to off and remove the key.
2. Raise the seat and lock it in the upright position.
3. Disconnect the negative battery cable from the battery terminal.
4. Slide the red boot off of the positive battery terminal and remove the positive battery cable.

CHARGING THE BATTERY

 **WARNING:** Charging the battery produces explosive gases. Never smoke near the battery and keep sparks and flames away.

IMPORTANT: Always keep the battery fully charged. This is extremely important when the temperature is below freezing. (32 degrees Fahrenheit or 0 degrees Celsius)

1. Remove the battery from the battery compartment under the seat. (see "Removing The Battery")
2. Check the electrolyte level.
3. Make sure the filler caps have been reinstalled on the battery and charge the battery 10-15 minutes on 25-30 amps or 30 minutes at 4-6 amps.
4. After the battery has been fully charged, disconnect the charger from the power source and then disconnect the battery from the charger.
5. Install the battery in the machine and connect the battery cables.

CLEANING BATTERY AND TERMINALS

 **CAUTION:** The battery produces a flammable and explosive gas. The battery may explode. Do not smoke near the battery. Always wear eye protection and

gloves. Do not allow direct metal contact across the battery posts. Always remove the negative battery cable first when removing the battery.

1. Disconnect and remove the battery.
2. Wash the battery with a solution consisting of four tablespoons of baking soda to one gallon of water. Use caution to insure the solution does not get into the battery cells.
3. Rinse the battery with plain water and allow to dry.
4. Clean the terminals and wire ends with a wire brush until they are bright.
5. Reinstall the battery.
6. Reattach the battery cables.
7. Apply a petroleum jelly or a silicone spray to prevent corrosion.

REPLACING FUSES

IMPORTANT: Avoid damage to the electrical circuit. Use only the same size fuse as was originally installed.

There are two fuses on your **EverRide** mower. On the Kawasaki 25 H.P. unit, one is located on the plastic shroud on the left hand side of the engine and the other is located on the left hand side of the frame next to the starter solenoid. Both are 20 amp fuses.

On the Kohler 27 H.P. engine, one 20 amp fuse is located on the engine shroud on the left hand side of the engine and the other one is an AGC 30 amp fuse which is part of the engine harness.

1. Remove the defective fuse from the socket.
2. Check the metal clip in the fuse window and discard the fuse if it is broken.

3. Install the new fuse in its socket.

SAFETY CHECKS

Check all safety switches daily. Use the following instructions to check the performance of the system. If any of these tests should fail, it is necessary to have the unit repaired immediately.

1. Try to start the power unit when the operator is in the seat, the mower PTO off, and the left hand motion control arm not in the park position. Try to start the power unit after switching the RH arm out of the park position and putting the LH motion control arm into the park position. Try starting the power unit after taking both arms out of the park position. The starter must not crank in any of these instances.
2. Try to start the power unit when the operator is in the seat, the mower PTO on, and the motion control arms in the park position. The starter must not crank in this situation.
3. Try to start the power unit when the operator is not in the seat and the motion control arms are in the park position. The starter must not crank in this situation.

CHECKING THE KILL CIRCUITS

Check the kill circuits daily.

1. Run engine at 1/3 throttle, engage the mower PTO and lift off of the seat. The engine should stop within 3 seconds.
2. Run engine at 1/3 throttle, engage the mower PTO, move a motion control arm out of the neutral lock and lift off of the seat. The engine should again stop within 3 seconds. Repeat for the opposite motion control arm.

NOTE: If the machine does not pass this test, **DO NOT OPERATE.** Take it to your **EverRide** Service Dealer.

LIFT ASSIST SPRING



CAUTION: The lift assist spring can be under extreme pressure. Exercise extreme caution when adjusting or replacing this spring.

The deck lift assist spring is installed to help maximize deck performance and minimize driver fatigue.

To adjust the lift assist spring, lower the mower deck to the lowest position. Adjust the spring by torquing the nut until the deck wants to raise off of the ground and then back the nut off one turn.

NEUTRAL ADJUSTMENT

Before making any adjustments, be sure to check the tire air pressure. Incorrect air pressure can cause the unit to pull to one side. The correct air pressure is 20 p.s.i. in the front wheels and 12 p.s.i. in the rear.

1. Stop the engine and remove the ignition key.
2. Tilt the seat forward.
3. Move the control lever rearward and release the control lever. This control lever should return to a position where the control lever can be swung outward and lock in the neutral outward position.
4. If adjustment is needed, move the control lever back to the inward position and begin to pull rearward. At this beginning rearward motion the clevis pin should begin to contact the end of the slot and start putting pressure on the spring.
5. If adjustment is needed, loosen the nut against the yoke and while applying slight rearward pressure on the motion control lever, turn the head of the adjustment bolt in the appropriate direction until the lever is centered.

6. Move the control lever rearward and release the control lever. This control lever should return to a position where the control lever can be swung outward and lock in the neutral outward position.

SERVICING THE CASTER WHEEL ROLLER BEARINGS

1. Park the unit on a level service, put the motion control arms in the park position, turn off the engine and remove the key.
2. Raise the front of the power unit and support it with jackstands.
3. Remove the lock nut, bolt and wheel assembly from the wheel fork assembly.
4. Remove the seals, bearings and the spacer tube from the wheel assembly.
5. Clean and inspect the bearings and pack with clean grease. Replace bearings as needed.
6. Install the spacer tube, bearings, and new seals.
7. Install the wheel assembly using the bolt and locknut removed in step 3.

SERVICING THE CASTER PIVOT BEARINGS

1. Park the unit on a level surface, put the motion control arms in the park position, turn off the engine and remove the key.
2. Raise the front of the power unit and support it with jackstands.
3. Remove the cap (2), the 3/4 locknut (24), the three 3/4 belleville washers (15), and the front wheel weldment (9).

NOTE: It is not necessary to remove the bearing cup unless the bearings need to be replaced.

4. Remove the lower seal (4) and the lower bearing (6).
5. Remove the upper bearing.
6. Clean and inspect the bearings and pack with clean grease. Replace the bearings if needed.
7. Reinstall the lower bearing and a new seal.
8. Reinstall the upper bearing.

NOTE: Do not overtighten the 3/4 locknut. Tighten the locknut only enough to remove any excessive play from the bearings.

9. Apply grease to the grease fitting until grease appears at the top bearing. Reinstall the cap.

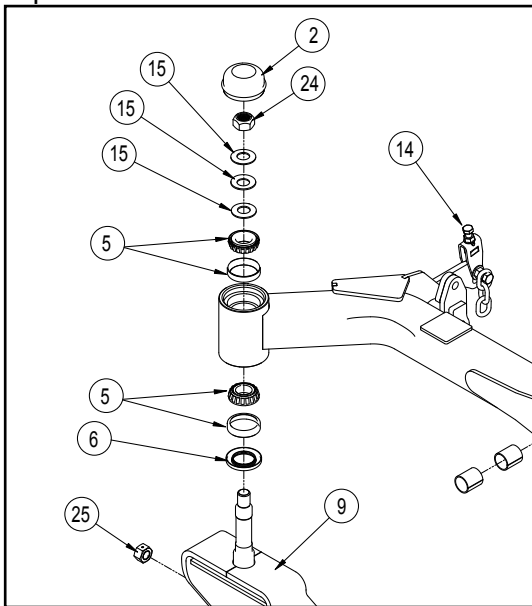

MOTION CONTROL ADJUSTMENT

When the unit is in motion and one arm is more forward than the other when driving in a straight line, the motion control arms are out of adjustment. While traveling, turn the tracking knob to the left or the right to increase or decrease the tractor wheel speed and make the motion control arms equal.

NOTE: The motion control arms need to be even in both neutral or park.

LEVELING THE DECK

CAUTION: Stop the engine, put the motion control arms in the park position and remove the key from the ignition before performing any maintenance or repairs on this unit.

1. Set the front tire pressure to 20 p.s.i. and the rear tire pressure to 12 p.s.i.
2. Place the mower on a level surface.
3. Raise the mower deck to the transport lock position and adjust the cut height to 3 inches.
4. Lower the deck back to cut position.
5. Set both of the outside blades to be perpendicular to the mower as shown.

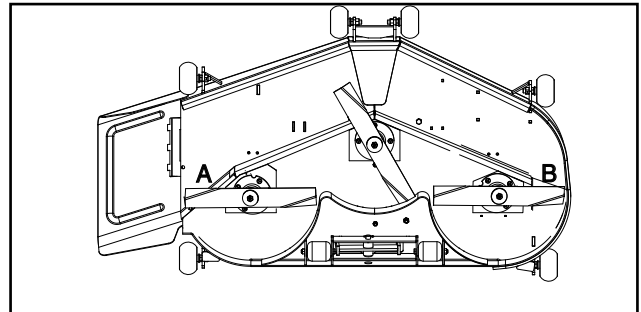

6. Measure the height of the blade tips on both A and B and adjust the front adjustment bolts and the rear U-bolts to insure the deck is level from left to right.
7. Rotate the mower blades so they are parallel to the mower deck. Use the rear adjustment bolts to adjust the deck so that the rear blade tip is 1/4" higher than the front blade tip on the same blade.

Measure the blade heights to make sure they match what is shown on the height of cut dial. The height is measured as the distance between the ground and the bottom of the blade. If the blade height does not match the dial height, see Synchronizing Height of Cut.

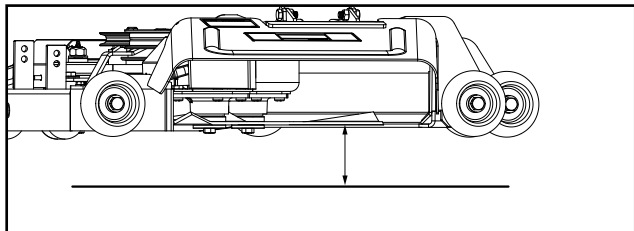

SYNCHRONIZING HEIGHT OF CUT



CAUTION: Stop the engine, put the motion control arms in the park position and remove the key from the ignition before performing any maintenance or repairs on this unit.

NOTE: It is necessary to insure the deck is level before synchronizing the height of cut dial with the deck blade height.

1. Raise the mower deck to the transport position. Take the weight off of the deck lift linkage by inserting wood blocks under each corner of the deck and slowly lowering it until it is resting on the blocks.
2. Loosen the 1/2-13 hex nut (1). If the blade height is lower than the height of cut knob, loosen the 1/2-13 x 1.75 (2) bolt which runs through the height of cut rotation adjustment weldment (3). If the blade height is higher than the height of cut knob, tighten the 1/2-13 x 1.75 bolt which runs through the height of cut rotation adjustment weldment.

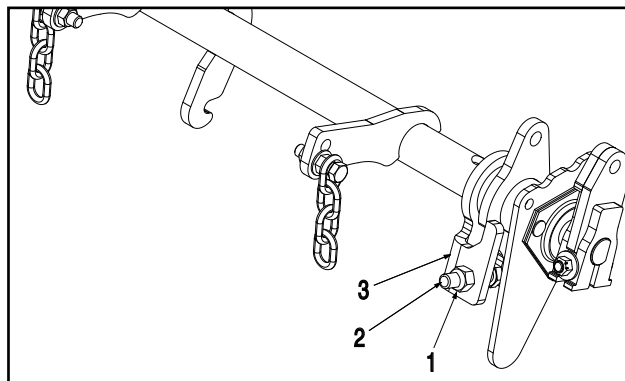

3. Tighten the 1/2-13 hex nut back down to lock it into position.
4. Raise the deck back to the transport height and remove the blocks from below the deck. Measure the blade height again to insure it now matches the height on the dial. If not, then repeat the prior steps until the two heights are synchronized.

DRIVE ADJUSTMENTS

Steering and motion controls should be uniform during forward and reverse motions. The motion control arms should always return to neutral when released from the reverse position.



CAUTION: Never make any adjustments unless the engine has been stopped, the motion control arms are in the park position, and the ignition key has been removed.

BRIGGS & STRATTON AIR CLEANER SERVICE - CARTRIDGE TYPE

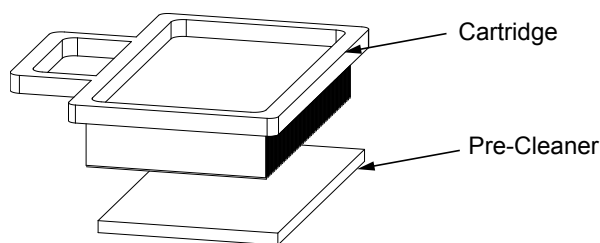

The air cleaner is top feed, so it is necessary to pull the air cartridge and pre-cleaner completely out to inspect the unit.

Reference the Briggs & Stratton operating and maintenance instructions for information on removal, cleaning and inspection.

BRIGGS & STRATTON AIR CLEANER SERVICE - CANNISTER TYPE

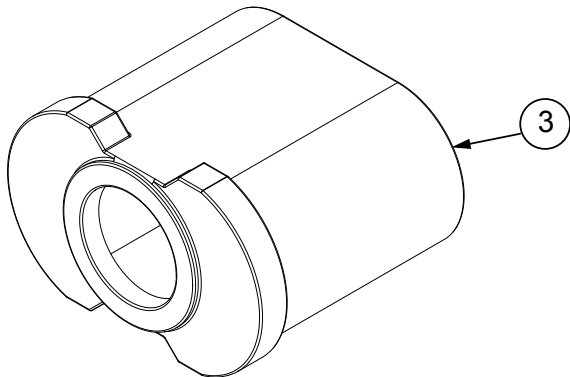

To remove, loosen the screws of the air cleaner cover and pull the cover off.

The air cleaner cartridge is located under the cover. To remove the cartridge, pull up along the outside edge until it snaps out.

Inspect the cartridge and brush off any dirt or debris. Clean engine around air cleaner area.

CAUTION: Do not use pressurized air or solvents to clean cartridge as they may damage the cartridge.

NOTE: This cartridge is surrounded by a thin foam sleeve. If this sleeve is torn or damaged, replace the entire cartridge.

CAUTION: Do not oil the foam sleeve or the cartridge. If there is oil or heavy debris on the cartridge, replace it.

Replace cartridge by aligning the hole of the cartridge with the air vent on the engine.

Push the cartridge in, toward the engine, until the cartridge snaps into place.

Reinstall air cleaner cover and tighten screws.

KAWASAKI AND KOHLER AIR CLEANER SERVICE

CAUTION: To prevent excessive engine wear, do not run the engine without the air cleaner installed.

IMPORTANT: The engine is air cooled and requires a large amount of air intake when running. Reduced air intake can cause overheating. Always keep air intake screen and cooling fins clean. Always keep the covers and screens in place.

CAUTION: Touching hot surfaces can burn skin. The engine and components will be hot after the unit has been running. Allow the engine and components to cool before servicing the unit.

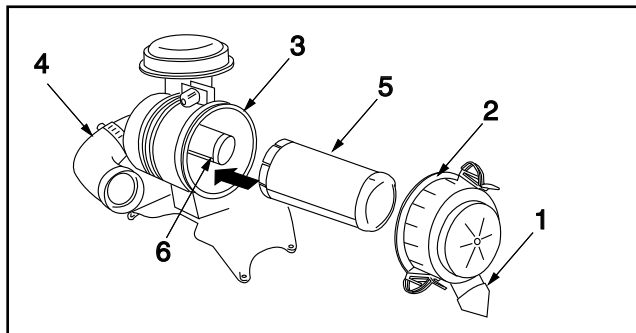

The Unloader Valve (1) will allow for the removal of fine dirt and dust from the canister body (3) without disassembly. While in operation, this valve will suck closed at 1/3 to 1/2 throttle.

- With the engine shut off, squeeze the valve by hand to release dust and debris.
- In very dusty operating conditions, the valve may have to be opened every 2 to 3 hours.

Remove the air cleaner cover and make a general inspection of the entire assembly. If it is unusually dirty or if dirt build-up is easily visible on the inside of the canister body, the entire assembly, including the inlet hose, must be removed from the carburetor and engine.

40 - LUBRICATION AND MAINTENANCE

With the air cleaner removed from the engine, and with the cartridges and gaskets removed, wash the hard parts with cleaning solvent and blow them dry with compressed air. **Do not wash the air cleaner cartridges!**

NOTE: If canister gaskets are broken or missing, BOTH air cleaner elements MUST be replaced.

Inspect and clean the primary air cleaner cartridge (5) assembly every 25 hours. Replace the paper element yearly or every 250 hours, whichever comes first.

The primary (large) cartridge is cleaned by rolling and “tapping” it on a hard surface. If the paper pleats are punctured or torn, the primary element must be replaced.

Replace the secondary cartridge (6) yearly or every 250 hours whichever comes first.

IMPORTANT: DO NOT attempt to clean the secondary element. This filter element must be replaced if it is unusually dirty or damaged.

NOTE: Operation in dusty conditions may require more frequent maintenance of the primary and secondary air cleaner cartridges.



CAUTION: Do not use pressurized air to clean paper element.

FUEL SYSTEM SERVICE



CAUTION: Fuel vapors are explosive and flammable. Do not smoke while handling fuel. Keep fuel away from flames or sparks. Shut off engine before servicing. Always work in a well ventilated area. Clean up spilled fuel immediately.



CAUTION: Be sure the engine is stopped, the motion control arms are in the park position and the key is removed before making these repairs.



CAUTION: Be sure to inspect the fuel lines periodically. The lines are subject to deterioration and wear. Fuel could leak out onto a running engine and cause a fire.



WARNING: Improper use of solvents can result in fire or explosion. Do not use gasoline or low flash point solvents to clean the fuel filter and/or the fuel pump. Clean only in a well ventilated area away from sources of sparks or flame, including any appliances with a pilot light.

IMPORTANT: Special care should be taken when the fuel lines are removed for maintenance or repair. Close both ends of the fuel line with a piece of paper or a clean cloth to prevent dust or dirt particles from contaminating the fuel. Even a small amount of dust or dirt can cause premature wear or failure of fuel components.

The fuel line connections are composed of rubber and they will age regardless of the service period. If there is any deterioration of the fuel lines or clamps, replace them.

Check the fuel filter regularly. If it is clogged by debris or contaminated with water, replace it.

The fuel filter cannot be disassembled. If the fuel filter becomes clogged, replace it with a new one.

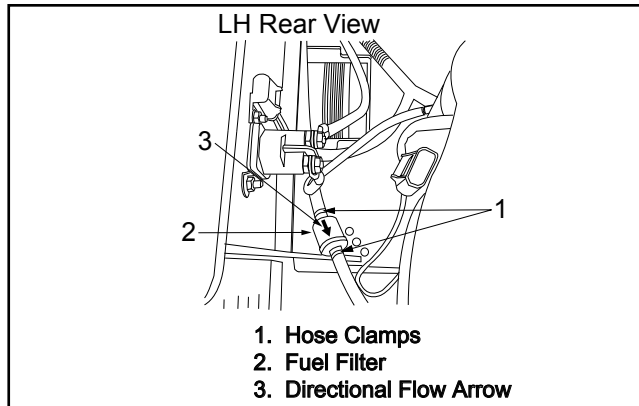

1. Park the machine safely.
2. Turn the fuel shut off valve to the OFF position.
3. Disconnect the hose clamps (1) from the fuel filter.
4. Slide the fuel line off of both ends of the fuel filter (2).
5. Install the new fuel filter paying close attention to the flow direction (3) noted on the fuel filter.
6. Turn the fuel shut off to the ON position.

The fuel pump can not be disassembled. If the fuel pump fails, replace it with a new one.

SPARK PLUG SERVICE

⚠ WARNING: Hot Engine components can cause severe burns. Stop engine and allow it to cool before checking the spark plug.

Clean or replace the spark plug and reset the gap every 100 hours of operation.

1. Disconnect the spark plug wire lead and remove the spark plug.

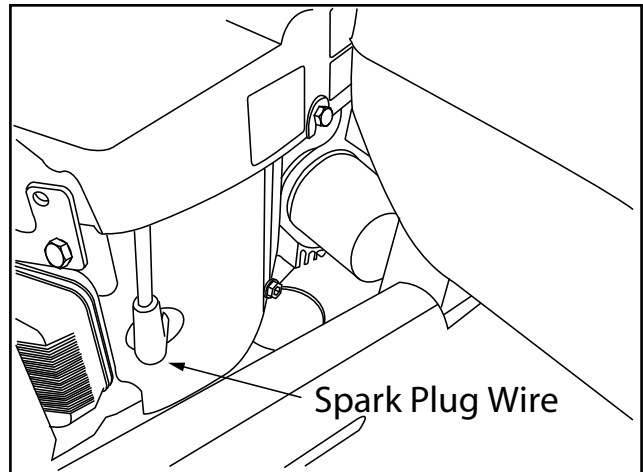

2. Clean the electrodes by scraping with a wire brush to remove carbon deposits.
3. Inspect for cracked porcelain or other wear and damage. If any wear or damage is evident, replace with a new spark plug.
4. Check the spark plug gap and reset if necessary. The correct gap should be .75 mm or .030 inches. To change the gap, bend only the side electrode using a spark plug tool.

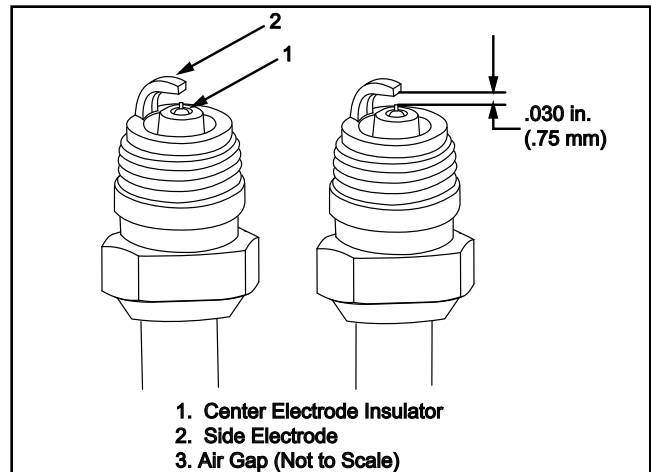

5. Install and tighten the spark plug to 22 N·m (16 ft. lbs.). Reconnect the spark plug wire lead.

See the engine operator's manual for the recommended spark plug for your engine.

COOLING SYSTEM CLEANING

42 - LUBRICATION AND MAINTENANCE

Before each use check to make sure the air intake screen is free from grass and debris and clean if necessary.

Every 100 hours, it is necessary to check and clean the cooling fins and inside the engine shrouds to remove grass, chaff or dirt clogging the cooling system and causing overheating.



CAUTION: Do not run the engine before all cooling system parts are reinstalled to keep the cooling and carburetion as intended.

SEASONAL STORAGE

Your **EverRide** mower represents an investment which you should get the greatest possible benefit. Therefore, when the mowing season is over, the mower should be thoroughly checked and prepared for storage so a minimum amount of time will be required to put it to work for the next season.

The following procedures are recommended for seasonal storage.

1. Thoroughly clean entire **EverRide** mower, especially the engine and the top and underside of the deck.
2. Remove, replace, or sharpen the mowing blades.
3. Check and adjust the deck belt.
4. Service the **EverRide** mower as noted on the lubrication schedule on page 28. Tighten all fasteners to the recommended torque, as shown on the Bolt Torque Chart on page 48.
5. Check the mower for damaged or excessively worn parts. Make replacements immediately with genuine **EverRide** service parts.
6. Power units to be stored over 30 days should be completely drained of fuel to prevent gum deposits from forming on essential carburetor parts, fuel filter, and the tank.

7. Repaint or spray touch up paint on the mower where necessary to prevent corrosion and to maintain the appearance. Replace all illegible safety decals.
8. Store the mower in a clean, dry location. If the mower will be removed for storage, make sure it is resting on blocks with the wheels raised from the ground or floor.
9. Change the power unit engine oil before the first use after storage. See "Changing the Engine Oil" on page 31.

FUEL SYSTEM DRAINING

Machines to be stored for over 30 days should have the fuel drained from the engine to prevent gum deposits from forming on essential carburetor parts, fuel filter, and tank.



WARNING: Gasoline is extremely flammable and can be explosive under certain conditions.



WARNING: Drain fuel before storing the unit for extended periods.



WARNING: Drain fuel in a well ventilated area away from any source of flame or sparks, including any appliances with a pilot light.



WARNING: Store fuel in an approved container in a safe location.

1. Clean every part of the engine thoroughly.
2. Be sure the key switch is in the "OFF" position.
3. Close the fuel valve and remove the sediment bowl.
4. Put a pan under the fuel valve to receive the drained fuel and open the fuel valve to drain the fuel from the fuel tank completely.

5. Reinstall the sediment bowl.
6. Gasoline is a toxic substance. Dispose of gasoline properly. Contact your local authorities for approved disposal methods.
7. Put a pan under the carburetor and loosen the drain screw of the carburetor to drain the fuel completely.
8. Tighten the drain screw.
9. Remove the spark plug and pour approximately 1-2 mL (.06 - .1 cu. in.) of engine oil through the spark plug hole and then screw the spark plug in after turning the engine a few times. Slowly turn the engine until you feel compression and then leave it there. This traps the air inside the cylinder and prevents rust inside of the engine.
10. Wipe the engine body with an oily cloth.
11. Change the engine oil for the next use after the period of storage. (refer to oil change page 31)

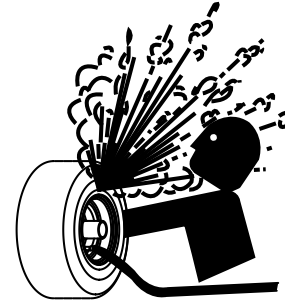

- ⚠ CAUTION:** Check the tires for low pressure, cuts, bubbles, damaged rims, or missing lug bolts and nuts.
- ⚠ CAUTION:** Always use a clip-on chuck with an extension long enough to allow you to stand on one side of the wheel while inflating the tires. Do not stand directly in front of the tire while inflating.
- ⚠ CAUTION:** Never weld or heat a tire and wheel assembly. The heat can cause the air inside of the tire to expand and result in a tire explosion. Welding also can structurally weaken or deform the wheel.

TIRE AND WHEEL MAINTENANCE

Visually inspect the tires each time before use. Be careful not to run the tires under or over inflated. This can cause tire damage. The correct tire pressure for the front tires is 20 p.s.i. and rear wheels is 12 p.s.i.

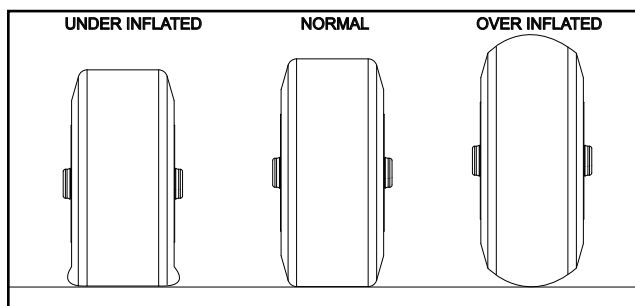

- ⚠ CAUTION:** Separation of a tire and rim can cause an explosion that could cause serious injury or death.

When reinstalling the wheel after service, be sure to torque the nuts to 75 ft. lbs. (101 N•m). Drive 200-250 yards and then re-torque.

BLADE MAINTENANCE

- ⚠ CAUTION:** Before removing the blades, be sure the engine has stopped and the key has been removed.
- ⚠ CAUTION:** The blades may be sharp. Wear gloves or wrap them in a towel before handling them.

Inspect the blades daily for straightness, sharpness, and balance. Replace the blades if they are cracked, worn, bent or out of balance.

44 - LUBRICATION AND MAINTENANCE

NOTE: Keep blades sharp. Mowing with dull blades will cause poor cut performance. It will also put additional strain on the engine by slowing the mower cutting speed.



WARNING: Never try to straighten a blade which has been bent or try to weld a blade that is cracked. Always replace with a new blade to assure safety.

To sharpen the blades, remove the blades by inserting a block of wood and turning the blade bolt counter clockwise.

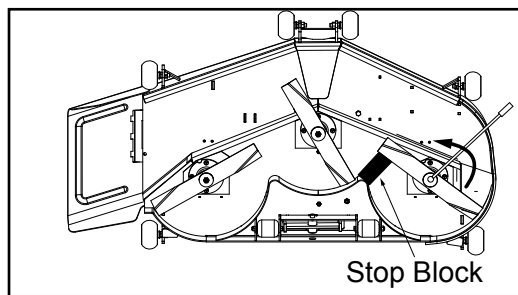

CAUTION: Always wear safety eye protection when sharpening the blades.

Be sure to wear a thick glove or wrap the blade in a towel to protect your hands from being cut. Insert the blades in a vise and use a mill file or grinder. File the blade along the original angle until the blade tip is at a 30° angle again.

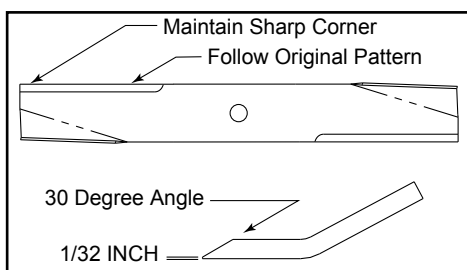

IMPORTANT: When sharpening blades, be sure to grind the same amount on each

side. Unbalanced blades will cause excessive vibration and could cause the spindles to wear prematurely.

Check the blade balance by inserting a horizontal rod through the center hole of the blade. The heavy side of the blade will drop down. Sharpen the heavy side of the blade until the blade is balanced.

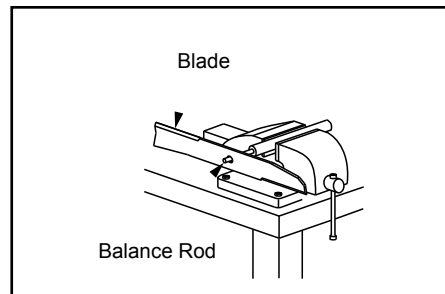

After sharpening, install the blades back onto the mower deck. Make sure the wings are facing up. Reinstall the blade bolt and lockwasher.

CLEANING GRASS BUILDUP FROM DECK



CAUTION: Before cleaning grass build-up, be sure the engine has stopped and the key has been removed.

Cleaning the underside of the deck regularly will help maintain deck cutting efficiency. Clean the underside of the deck as often as possible.

To gain access to the underside of the deck, depress the deck lift foot pedal and lock it in the transport position. Move the deck cut height adjustment to the highest setting. Raise the front of the power unit and support it with jackstands.

Clean out any grass buildup from under the deck and discharge shield.

BELTS - GENERAL INFORMATION

Inspect the belt pulley grooves and flanges for wear. A new belt, or one in good condition, should not "bottom out" in the pulley groove. Replace the belt when the belt touches the bottom of the groove otherwise the belt will slip excessively.

Always use caution when changing a belt. Never pry a belt to try to get it on a pulley. This could cut or damage the belt fibers.

Always keep oil and grease away from the belts and never use belt dressings. These materials will break down the construction of the belt and lead to premature failure.

Belts should be checked regularly, and replaced approximately at 250 hour intervals. Belts should also be replaced any time the belt(s) show evidence of cracking, missing pieces, friction burns from slipping, or other extreme damage. Small cracks or fabric polishing are normal.

Small branches and other similar debris can get onto the top of the deck, into the pulleys, which may cause the belt(s) to break or come off the pulleys. Make sure the area to be mowed is cleared of this debris, and make sure all belt guards are in place, before mowing.

To guarantee long life of the belts, always use genuine **EverRide** belts. Off the shelf belts (hardware store items) do not meet **EverRide** specifications for strength and longevity.

DRIVE BELT R & R

⚠ WARNING: Most service work requires the engine to be shut OFF. To prevent injury while working on the mower, remove the ignition key and disconnect the negative (-) cable from the battery.

1. With the deck in the transport position, raise the floor pan. To disengage the drive belt, latch the tension arm in its deck bracket. Roll the drive belt off the idler pulley.
2. Install a new drive belt, making sure it is routed according to the decal on the bottom of the floor pan. Unlock the belt tension arm so the belt is tensioned and ready for operation.

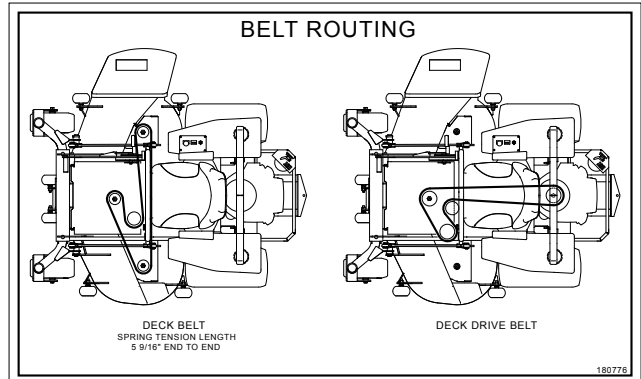

3. Lower the floor pan.

DECK BELT R & R

1. Disconnect the drive belt according to “Drive Belt R & R instructions.”
2. Remove the 3/8-16 x 2 1/2 bolt and 3/8-16 locknut from under the pulley standoff arm, remove the arm, making sure the pivot bushings do not fall out or get lost.
3. Release tension on the deck belt by backing off and releasing the belt tension rod.
4. Remove both belt shields and remove the deck belt.
5. Install a new deck belt, routed according to instructions found on the decal on the bottom of the floor plate.
6. Reconnect the deck belt tension rod and tighten the 3/8-16 nut until the tension spring measures 5 9/16” from hook end to hook end. Tighten the other nut against the rod bracket to lock this adjustment. Install both deck belt shields.
7. Reinstall the drive belt idler pulley standoff arm, insuring the rod end is inserted in its bracket near the clutch. Lightly lubricate the pivot bushings with MP Lithium grease, install and retain with the removed 3/8-16 fasteners.
8. Reinstall or reconnect the drive belt according to “Drive Belt R & R.”

PUMP BELT R & R

1. Make sure the mower is on a firm level surface, the PTO switch is off, the engine is shut off, the motion control levers are in the park position, the negative battery cable is removed, and the lift control lever is unlocked.
2. Place the deck in the highest position.
3. Release the deck belt tension by loosening the tension spring. Remove the belt from the electric clutch. It is not necessary to remove the belt from any other pulleys.
4. Release the tension from the pump belt by shortening the belt tension spring. Pull back on the tension arm and pull the belt out from behind the pulley. Use caution when releasing the belt tension arm as there will still be pressure on the arm.
5. Slide the belt off of the engine pulley. The belt will have to be slid above the engine pulley to allow the belt to be removed from the other pulleys.
6. Slide the belt off of the pump pulleys and it now should slide easily off of the engine pulley.
7. Install the new belt by sliding it above the engine pulley. Route the belt as shown below.
8. Pull the idler pulley on the tension arm back and slide the belt under the pulley.
9. Re-tension the spring by making sure it is extended to 6".
10. Reinstall the deck belt drive on the clutch and make sure it is routed properly on all pulleys.
11. Re-tension the deck belt idler using the deck belt tension explanation on page 45.
12. Reattach the negative battery cable.

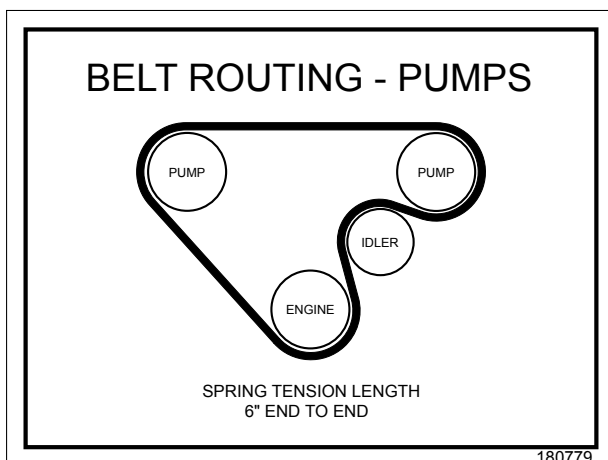

48 - BOLT TORQUE CHART

FASTENER TORQUES

Mounting bolts and fasteners may tend to work loose during operation due to vibration or stress. A visual check of the complete mower should be made daily. All fasteners should be checked for correct retention torque, weekly, and more often if the unit is being operated in rough areas.

All locally procured fastening hardware should be Grade 5 or equivalent. Use the following chart for general torque specifications for Grade 5 standard fasteners. Special fastener torques for the mower are shown separately below.

SAE Grade 5

| Fastener Size | lbs.-ft. | | N-m | |
|---------------|------------|-----|------------|-----|
| | Lubricated | Dry | Lubricated | Dry |
| 1/4-20 | 7 | 9 | 9 | 12 |
| 5/16-18 | 15 | 20 | 20 | 27 |
| 3/8-14 | 30 | 35 | 41 | 47 |
| 7/16-14 | 45 | 55 | 61 | 75 |
| 1/2-13 | 60 | 80 | 81 | 108 |
| 9/16-12 | 100 | 120 | 136 | 163 |
| 5/8-11 | 130 | 170 | 176 | 231 |
| 3/4-10 | 220 | 300 | 298 | 407 |

Metric Class 8.8 or 9.8

| Fastener Size | lbs.-ft. | | N-m | |
|---|------------|-----|------------|-----|
| | Lubricated | Dry | Lubricated | Dry |
| M8 | 17 | 20 | 23 | 27 |
| M10 | 34 | 40 | 46 | 54 |
| M12 | 55 | 70 | 75 | 95 |
| M14 | 90 | 110 | 122 | 149 |
| M16 | 145 | 175 | 197 | 237 |
| M20 | 280 | 350 | 380 | 475 |
| "Lubricated" means coated with a lubricant such as engine oil | | | | |
| "Dry" means plain or zinc plated without any lubrication | | | | |

IMPORTANT:

Torque values SHOULD NOT be followed when fastening plastic parts!

SPECIAL FASTENER TORQUES

IMPORTANT:

DO NOT use the pulley nut to hold the shaft from turning during blade tightening, as the pulley nut will be over torqued which could cause spindle spacer and bearing damage.

| | |
|--|-----------------------------------|
| Mowing Blade Retaining Bolt - Grade 8 (9/16-12 x 1-3/4) | 110 to 130 ft. lbs. (150-177 N•m) |
| Spindle Pulley Retaining Nut (3/4-16 UNF) | 80 ft. lbs. (109 N•m) |
| Spindle Housing Retaining Nuts (7/16-20 UNF) | 35-45 ft. lbs. (48-61 N•m) |
| Wheel Nuts (1/2-20 Lug Nuts)..... | 75 ft. lbs. (101 N•m) |

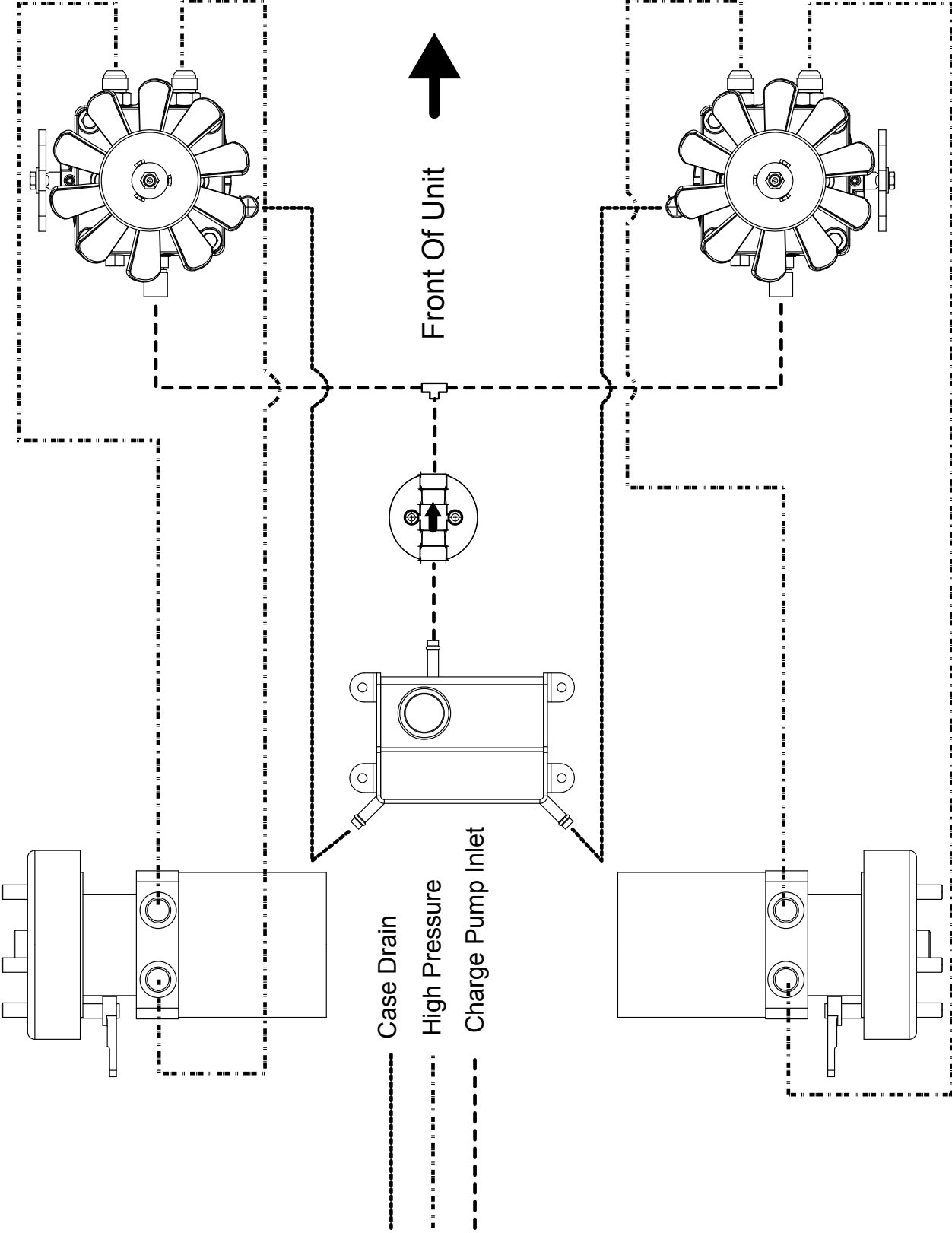

50 - ELECTRICAL SCHEMATIC

ACTUAL CONNECTIONS

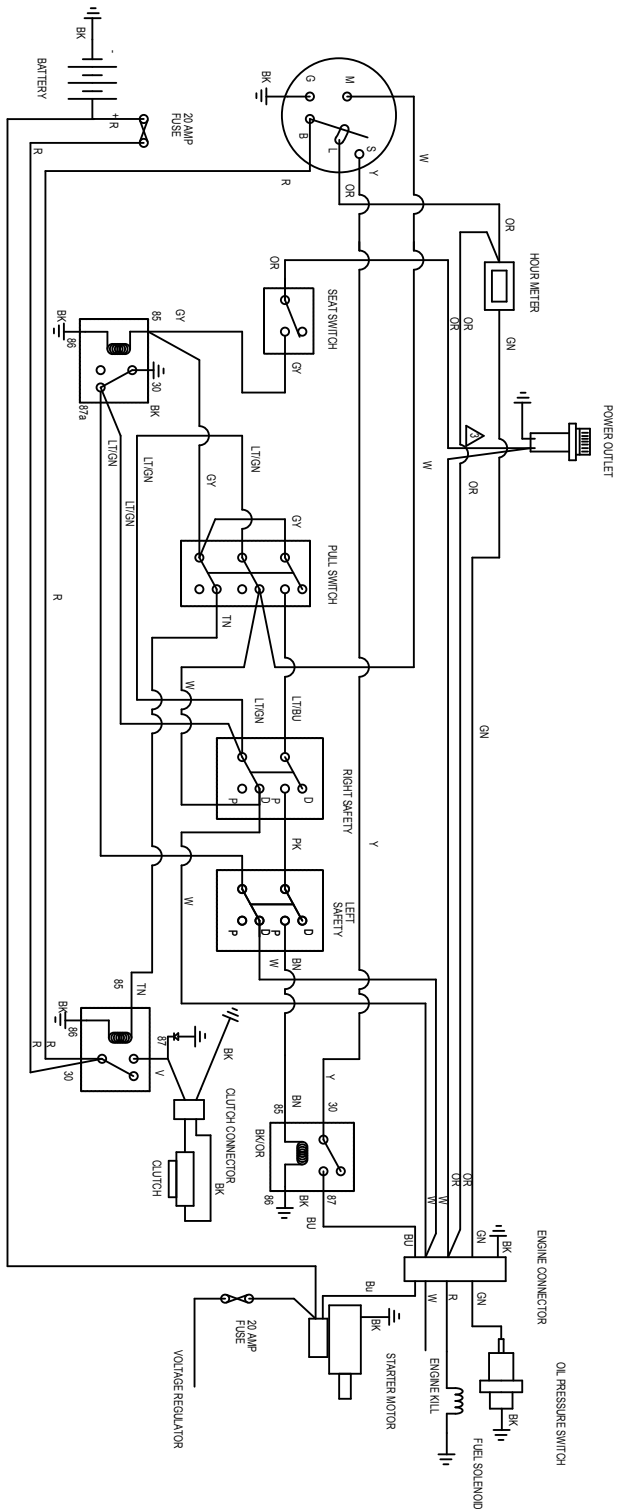

SCHEMATIC

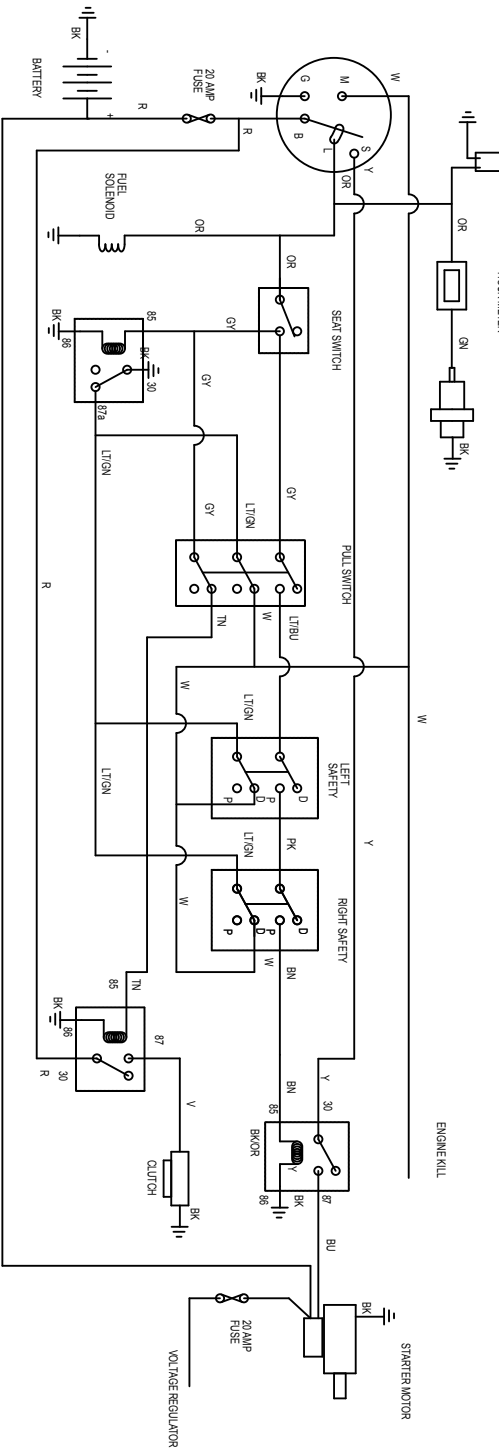

- W WHITE
- BK BLACK
- BR BROWN
- R RED
- OR ORANGE
- Y YELLOW
- GN GREEN
- BU BLUE
- V VIOLET
- GY GRAY
- TN TAN
- PK PINK
- LT LIGHT GREEN
- LTBL LIGHT BLUE

The following troubleshooting guide is for the mower deck and its drive. This assumes the power unit engine is running to prescribed specifications. Consult the mower repair reference for all system checks.

Before attempting repair or test, observe the general condition of the power unit and mower. Make certain the power unit is operating properly and the mower is setup correctly. The following information may give you some hints in what to look for when attempting to solve a problem with the mower. If the problem cannot be easily solved, contact your **EverRide** dealer.

| SYMPTOM | PROBLEM | CORRECTION |
|-------------------------------|---|--|
| Excessive Vibration. | Loose spindle/blade fasteners. | Re-torque or replace as necessary. |
| | Blade interference with grass buildup in deck. | Clean the underside of the deck. |
| | Blades out of balance. | Balance blades according to instructions found on page 44. |
| | Blade(s) broken or worn badly. | Replace mowing blades in sets of 3. |
| | Engine mounting bolts are loose. | Tighten the engine mounting bolts. |
| | Engine/Idler/Blade pulley loose. | Tighten the pulley. |
| | Engine pulley damaged. Failed spindle bearing | Contact dealer. Contact dealer. |
| Uneven Cutting Height. | Blades dull. | Sharpen or replace blades. |
| | Cutting blade (s) is/are bent. | Install new cutting blades. |
| | Deck is not level. | Level deck. |
| | Anti-scalp not set correctly. | Adjust height of anti-scalp wheel. |
| | Grass buildup under deck. | Clean underside of deck. |
| | Incorrect tire pressure. | Adjust psi to 12 p.s.i rear and 20 p.s.i. front. |
| | Blade spindle bent. Ground speed too fast. | Contact dealer. Lower ground speed. |
| Blades Wear Too Fast. | Cutting in sandy conditions. | Increase deck mowing height. |
| | Cutting in rocky conditions. | Increase deck mowing height. |
| | Heat treat has been removed by sharpening with grinder. | Replace mowing blades in sets of 3. |
| Not Cutting Clean. | Blades dull. | Sharpen or replace blades. |
| | Blades installed upside down. | Install blades correctly. |
| | Blade RPM too low. | Use full throttle position. |
| | Mower deck not level. | See cutting heights (page 24). |

52 - MOWER TROUBLESHOOTING GUIDE

| | | |
|--|--|---|
| | Mower tires mashing grass. | Tires under inflated (12 psi rear and 20 p.s.i. front). Too wet or lush to mow. Reverse direction and re-mow the area. |
| | Ground speed too fast. Excessive grass buildup under mower deck. | Reduce ground speed. Clean underside of deck. |
| Streaking or Windrow Conditions in Swath. | Blades dull. Blades installed upside down. Conditions too wet for mowing. Excessive grass buildup under mower deck. Ground speed too fast for conditions. | Sharpen or replace blades. Install blades correctly. Allow grass to dry before mowing. Clean underside of deck. Lower operating speeds. |
| Blades Don't Rotate. | Deck belt is worn, loose or broken. Deck belt off pulley. Clutch Failed. | Install new deck belt. Reinstall deck belt. Contact dealer. |
| Mower Loads Power Unit. | Engine RPM too low. Ground speed too fast. Excessive grass buildup under mower deck. | Use full throttle position. Reduce ground speed. Clean underside of deck. |
| Excessive Noise. | Grass and lawn debris buildup under the deck will cause excessive noise as the mower blades will contact the eventual hardened buildup. Clean the underside of the deck regularly, especially if the mowing conditions were wet or extremely lush. | |

| SYMPTOM | PROBLEM | CORRECTION |
|--|--|--|
| Engine Idling Poorly. | Carburetor adjusted incorrectly. Improper spark plug gap. | Readjust carburetor. Check and re-gap plugs. |
| Engine Backfires. | Carburetor adjusted incorrectly. | Contact dealer. |
| Engine Runs But Won't Move. | Drive belt loose or broken. Hydrostatic reservoir oil low. Pump bypass valve open. Hydrostatic oil filter plugged. Bad pump or motor. | Tighten or replace the drive belt. Refill reservoir. Put in closed position. Replace filter. Contact dealer. |
| Power Unit Loses Power or Hydrostat System Overheats. | Hydrostatic oil reserve too low. Pump or motor damaged. Hydrostatic oil reservoir blowing oil out of cap. | Refill reservoir. Contact dealer. Overfill or water contaminated. |
| Loss of Power or System Will Not Operate in Either Direction. | Restrictions in air cleaner. Poor compression. Steering linkage needs adjustment. Hydraulic bypass valve open. Pump belt broken or worn. Pump belt off of pulley. | Service air cleaner. Contact dealer. Contact dealer. Close the bypass valve. Replace belt. Reinstall belt on pulley. |
| Engine Overheating. | Air intake screen clogged. Cleaning fins clogged. | Service air intake screen. Clean fins. |
| Engine Stalling While Blades are Engaged. | Operator not in seat. Faulty safety system. Spindle bearing failure. Blades locked by foreign matter. | Sit on seat. Contact dealer. Contact dealer. Clean underside of deck. |
| Low Engine Oil Pressure. | Low oil level. Oil diluted or too light. | Add oil. Change oil and locate source of contamination. |
| High Oil Consumption. | Numerous possible causes. | Contact dealer. |
| Engine Will Not Turn Over. | Dead battery. Bad ground connection. Poor terminal connection at battery. Poor wiring harness connections. Bad park switch. Bad PTO switch. Motion control arms not in park position. PTO switch engaged. Operator not in seat. Blown Fuse. | Charge unit or jump start. Correct the connection. Correct the connection. Correct the connection. Contact dealer. Contact dealer. Put arms in park. Disengage PTO switch. Sit in seat. Replace fuse. |

54 - MOWER UNIT TROUBLESHOOTING GUIDE

| SYMPTOM | PROBLEM | CORRECTION |
|--|---|--|
| Engine Turns Over But Doesn't Start - There Is a Spark At Plug. | No fuel or line plugged. Bad fuel solenoid. Fuel valve turned off. Dirt in fuel filter. Dirt, water, or stale fuel. Incorrect fuel in fuel system. Choke is not on. | Fill tank or replace line. Contact dealer. Turn fuel valve on. Replace fuel filter. Contact dealer. Drain tank and replace with proper fuel. Move choke lever to on. |
| Engine Turns Over But Doesn't Start - No Spark at Plug. | PTO switch is on. Control levers are not in park. No operator in seat. Bad seat switch. Bad park switch. | Turn PTO switch off. Put levers in park. Sit on seat. Contact dealer. Contact dealer. |
| Power Unit Jerky When Starting or Operates in One Direction Only. | Motion control linkage needs adjustment. Hydrostatic pump failure. Wheel motor failure. Bypass valve open. | Contact dealer. Contact dealer. Contact dealer. Close bypass valve. |
| Power Unit Creeps When Motion Control Arms are in Neutral. | Motion control linkage needs adjustment. | Contact dealer. |
| Power Unit Circles or Veers. | Motion control linkage needs adjustment. Hydrostatic pump failure. Wheel motor failure. Tires improperly inflated. | Contact dealer. Contact dealer. Contact dealer. Adjust front tire pressure 20 psi and rear tires to 12 psi. |
| Abnormal Vibration. | Engine mounting bolts loose. Loose engine pulley. Engine pulley damaged. | Torque engine bolts. Tighten pulley. Contact dealer. |

SETUP INSTRUCTIONS

EverRide mowers are shipped partially assembled. After uncrating the power unit and mower deck, initial setup is required.

IMPORTANT: During the unpacking of the crate all goods should be matched against the packing list and all shortages or damages should be noted and reported to the carrier immediately. The carrier will provide directions for filing a claim to receive compensation for damage.

1. Remove all packaging.
2. The motion control arms have been loosened and moved forward during packaging. Remove the loose 3/8-16 x 1.75 bolts from the handles and reinstall them in the location shown.

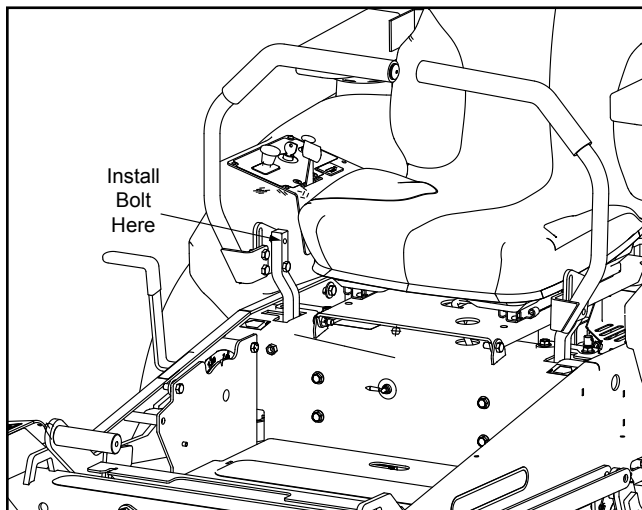

3. The seat lock lever has also been disconnected to allow the seat to go completely forward. Remove the loose 3/8 clevis pin, flat washers and rue ring from the seat lock lever.

4. Carefully rotate the seat back far enough to facilitate installation of the seat lock lever in the location shown below.

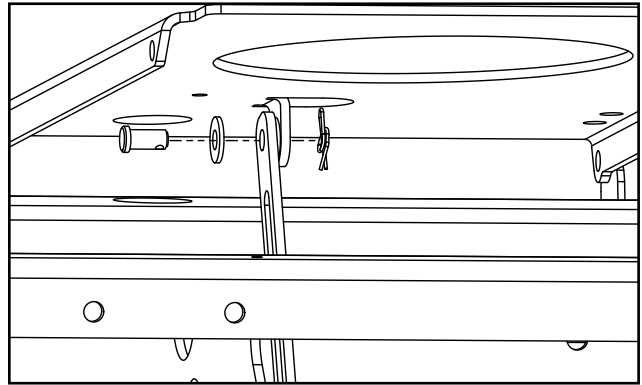

5. Connect the seat lock lever to the seat plate by inserting the 3/8 clevis pin through a 3/8 flat washer, through the seat lock lever, through another 3/8 flatwasher, through the seat plate and secure

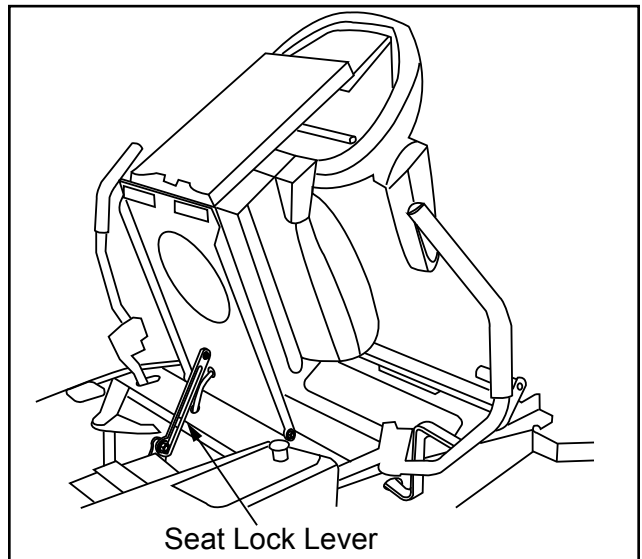

5. Torque all hardware to 25 ft. lbs.

BATTERY INSTALLATION

The battery supplied with your EverRide Warrior mower is sealed, it will not be necessary to activate it. If the engine does not turn over by turning the ignition switch, it may be necessary to charge the battery.

HYDRAULIC OIL SERVICE

The power unit is shipped with hydraulic oil in the system. If the tracking is erratic, make sure the dealer purges the system according to the repair manual instructions. If the oil level is low, below the edge of the baffle in the oil reservoir, fill with SAE 20W-50 motor oil.

ASSEMBLING THE FULL VISION FIXED ROPS

Pull the tractor onto a level surface, put the tractor motion control arms in the park position. Turn the engine off and remove the key.

Assemble the ROPS by sliding the splice tube (3) into both the left hand ROPS assembly (1) and the RH ROPS assembly (2). Insert the four 3/8-16 hex bolts through four 3/8 lock washers, through four 3/8 flatwashers, through the ROPS assembly and into the splice tube. **DO NOT TORQUE** until installation is complete.

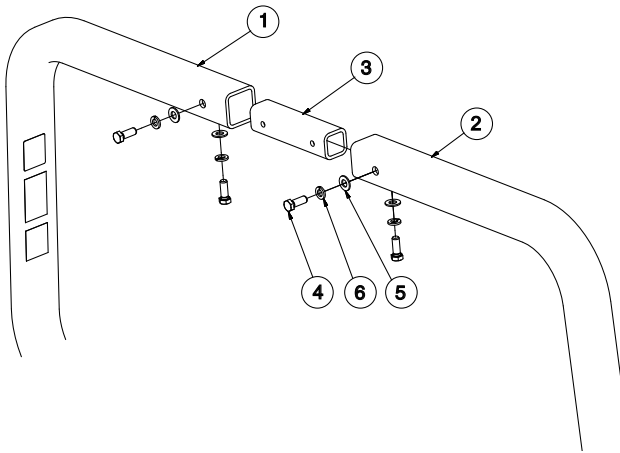

Assemble the seat belt to the ROPS by inserting the 7/16-20 x 1 hex bolt through a 7/16 flat washer,

through the seat belt and through the ROPS weldment. Secure with a 7/16 flat washer and a 7/16-20 lock nut.

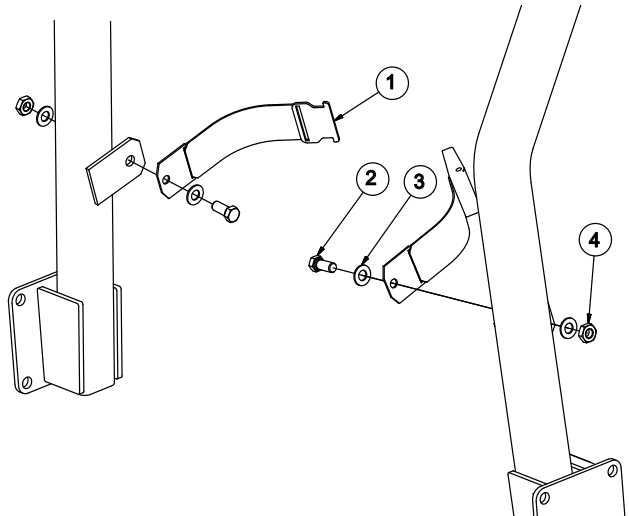

ASSEMBLING THE FOLDING FULL VISION ROPS

Slide the ROPS formed tube (3) into the RH folding base weldment (1). Insert the 1/2-13 x 3.5 bolt (5) through the RH folding base weldment (1), through the ROPS formed tube and through the RH folding base weldment again. Secure it in place with a 1/2-13 hex nut (7). Insert the pin assembly (2) through the RH folding base weldment, through the formed tube ROPS and through the RH folding base weldment again. Secure with a lynch pin (6). Insert the 3/8-16 x 1.5 knob (8) through the RH folding base weldment and into the formed tube ROPS. Do not torque the hardware until the ROPS is attached to the tractor.

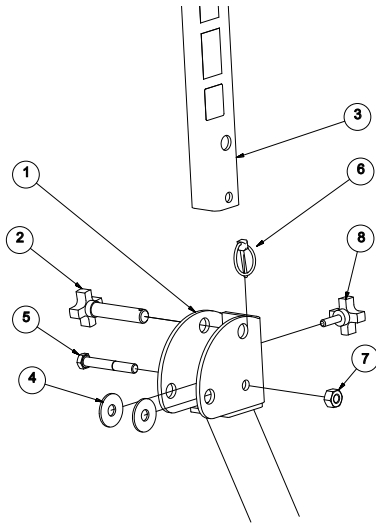

Assemble the seat belt to the ROPS by inserting the 7/16-20 x 1 hex bolt through a 7/16 flat washer, through the seat belt and through the ROPS weldment. Secure with a 7/16 flat washer and a 7/16-20 lock nut.

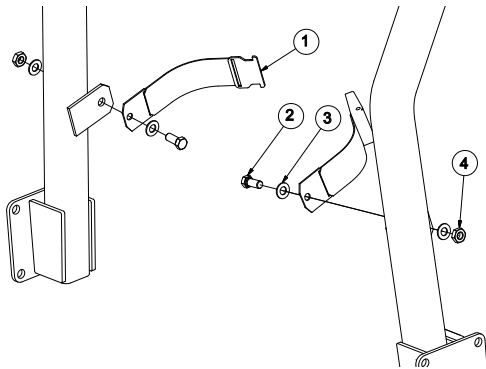

ATTACHING THE ROPS TO THE MOWER

Using a hoist or a jack, raise the rear of the tractor off of the ground. Insert floor jacks under the axle to support the weight of the tractor. Remove the five lug nuts securing the wheel to the wheel hub.

Slide the ROPS assembly along the inside of the mower frame. Insert the 1/2-13 x 2.5 bolts (1) through the LH bolt holes on the tractor frame and through the ROPS. Secure in place with 1/2 lock washers and 1/2-13 hex nuts. Insert the 1/2-13 x 1.5 bolts through the RH bolt holes on the tractor

frame and through the ROPS. Secure with 1/2 lock washers and 1/2-13 hex nuts.

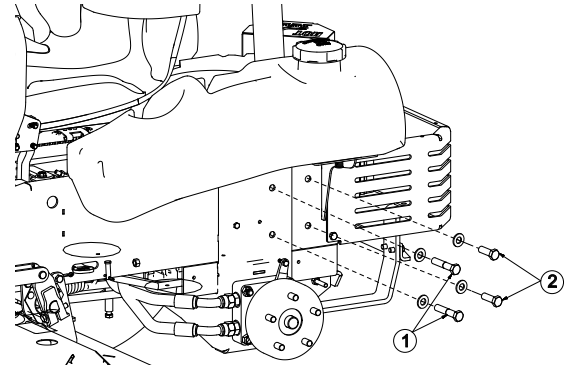

Torque all hardware using the torque values in the torque chart on page 48.

ATTACHING THE FEMCO ROPS TO THE MOWER

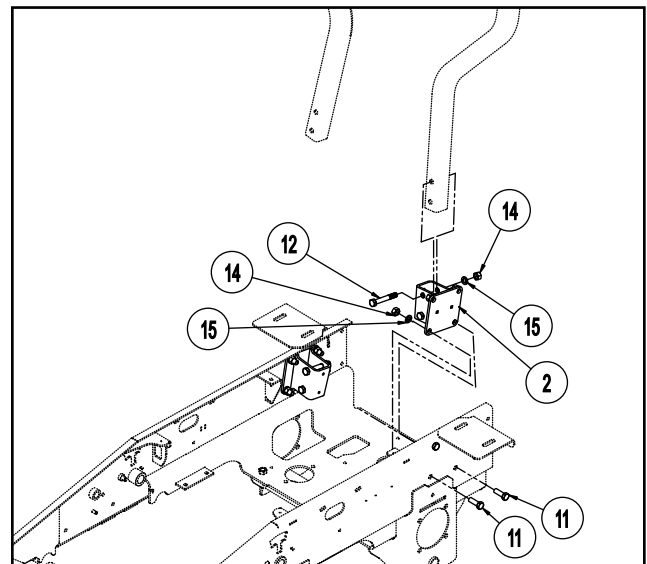

Using a hoist or a jack, raise the rear of the tractor off of the ground. Insert floor jacks under the axle to support the weight of the tractor. Remove the five lug nuts securing the wheel to the wheel hub.

Install the LH ROPS mount pocket (2) to the inside of the mainframe above the wheel motor, with the pocket tipped outward at the top. Loosely secure with four 1/2-13 x 1 1/2 bolts (11) and retain with

58 - MOWER ASSEMBLY INSTRUCTIONS

1/2" lockwashers (15) and 1/2-13 standard hex nuts (14). DO NOT TORQUE. Repeat for the RH ROPS mount pocket.

Raise and place the ROPS posts into the pockets. Loosely install 1/2-13 x 3 1/2 bolts (10) through the pockets and ROPS posts and retain with 1/2 inch lockwashers (13) and standard 1/2-13 hex nuts (14). Torque 1/2-13 x 3 1/2 bolts to 100 ft. lbs. (138 N·m)

If a folding ROPS is to be installed, the top must be installed so it tips rearward.

Torque all hardware using the torque values for grade 5 hardware in the torque chart on page 48.

Reinstall the rear wheels to the wheel hub and lower the mower back to the ground.

NOTE: Both the folding and fixed ROPS will come with a 181592 star knob. It is only used with the folding ROPS.

ATTACHING THE SEAT LATCH & SEAT BELT FOR FEMCO ROPS

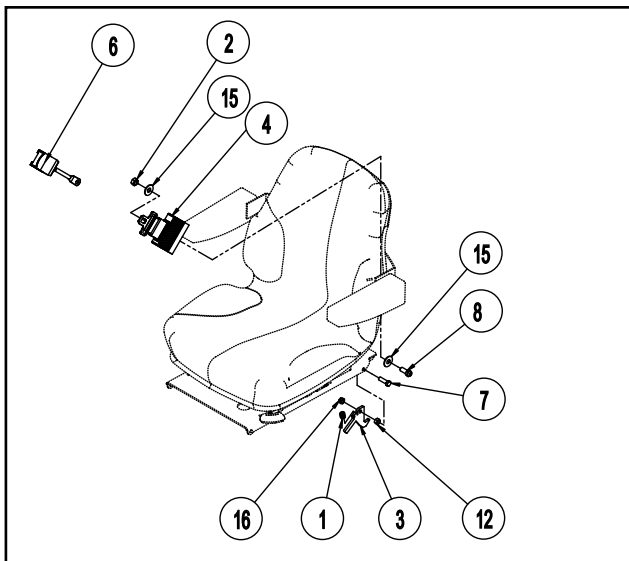

Install the Seat Latch (3) by inserting a 3/8-16 x 1.25 Hex Bolt (7) through the Seat Plate, through

a 3/8-16 hex nut (12), and through the seat latch (3). Secure with a 3/8-16 crown locknut (16).

Place the compression spring on the Warrior latch as shown and place the latch over the bolt through the seat plate. Tighten so the latch will pivot freely.

Install the seat belt bracket ends to the mounts on either side of the seat, just below the arm rest hinge points. Insert a 7/16-14 x 1 bolt (8) through a 7/16 flat washer (15), through the seat bracket and through the seat belt bracket (4). Secure with a 7/16 flatwasher (15) and 7/16-14 crown locknut (2).

NOTE: The retractable seat belt should be installed on the LH side of the seat to eliminate interference with the console.

Torque all hardware using the torque values for grade 5 hardware in the torque chart on page 48.

EVERRIDE WARRIOR MOWER

Engine

| | |
|---------------------------|--|
| Manufacturer | Kawasaki™ Model FH721V Kohler™ Model CV740 Briggs and Stratton™ Model 4468770121E1 |
| Type | V-Twin Air Cooled 4-Stroke OHV |
| Displacement | 41.2 Cubic Inch (675 mL) Kawasaki 44.0 Cubic inch (725 mL) Kohler 44.2 Cubic inch (724 mL) Briggs and Stratton |
| Horsepower | 25 H.P. Kawasaki 27 H.P. Kohler 26 H.P. Briggs and Stratton |
| Maximum Torque | 41.3 ft. lbs. Kawasaki 42.7 ft. lbs. Kohler 33 ft. lbs. Briggs and Stratton |
| Maximum Recommended Speed | 3600 RPM |
| Bore | 2.96 in. (75.2 mm) Kawasaki 3.3 in. (83 mm) Kohler 3.12 in. (79.25 mm) Briggs and Stratton |
| Stroke | 2.99 in. (76 mm) Kawasaki 2.6 in. (67 mm) 2.89 in. (73.4 mm) |
| Cylinders | Two - V-Twin |
| Direction of Rotation | Clockwise Facing the PTO Shaft |
| Crankcase Capacity | 1.9 Quart (1.8 Liters) Kawasaki 2.0 Quart (2.0 Liters) Kohler 2.0 Quart (1.9 Liters) Briggs and Stratton |
| Fuel Type Ethanol | Unleaded Gasoline (Min. 87 Octane) |
| Fuel Tank Capacity | (Both Tanks) 11.83 Gallons (44.8 liters) |

Electrical System

| | |
|----------------------|---|
| Battery | 12 Volt DC 400 CCA |
| Charging System | Charge Coil |
| Charging Output | 15 Amp |
| System Polarity | Negative Ground |
| Starter | 12 Volt Electric Ring Gear Type, Bendix Drive |
| Fuse Protection | 20 Amp Automotive Buss Type (Yellow) |
| Power Take Off (PTO) | Ogura™ GT-3 Clutch Brake |
| PTO Blade Brake | Dry Single Disk |

Weights/Measurements

| | |
|-----------------------------------|-----------------------|
| Shipping Weight w/o Mower Deck ** | 885 pounds (401 kg) |
| Fixed ROPS Weight (Standard) ** | 68 pounds (31 kg) |
| Folding ROPS Weight (Optional) ** | 74 pounds (34 kg) |
| Overall Width w/o Mower Deck | 54 inches (1372 mm) |
| Overall Length | 80.5 inches (2045 mm) |

60 - SPECIFICATIONS

| | |
|--------------------------|-----------------------|
| Overall Height w/o ROPS | 49 inches (1245 mm) |
| Overall Height w/ROPS | 73.5 inches (1867 mm) |
| Wheelbase | 52 inches (1321 mm) |
| Minimum Ground Clearance | 5.5 inches (140 mm) |

Hydrostatic Drive System

| | |
|---------------------------|---|
| Steering | Two Motion Control Arms |
| Transmission | Two Axial Piston Pumps & Two Fixed Wheel Motors |
| Travel Speed | |
| Forward | Zero to 12 mph (19.30 km/h) |
| Reverse | Zero to 9 mph (14.48 km/h) ZBR2660S/ZKH2766S Zero to 4 mph (6.44 km/h) Zero to 3.5 mph (5.63 km/h) ZBR2660/ZKH2766S |
| Tires | |
| Rear Drive Tires, | 24 x 12-12 - 4 Ply Turf Tread |
| Front Caster, | 13 x 6.50-6 - 4 Ply Ribbed Tread |
| Deck Anti Scalp Rollers, | 5 inch Phenolic Material |
| Minimum Turning Radius | True Zero-Turn |
| Hydraulic System Capacity | 1 Gallon (3.8 Liters) |
| Parking Brake | Control Arm Actuated Drum/Shoe Brake System Integrated into Wheel Motors |

| Mower Deck | 54 Inch | 60 Inch | 66 Inch |
|----------------------|-----------------------|---|----------------------|
| Style | | High Volume Tunnel Deck | |
| Dimensions | | | |
| Weight ** | 272 lbs (123 kg) | 297 lbs (125 kg) | 322 lbs (127 kg) |
| Width | 55.5 inches (1410 mm) | 61.1 inches (1552 mm) | 67.4 (1712 mm) |
| Depth | | 5.5 to 7.75 inches (14-19.7 mm) | |
| Thickness | | Full 7 Gauge Welded Construction | |
| Deck Lift | | Foot Operated Spring Assist | |
| HOC Adjustment | | Fingertip Control Dial Gauge | |
| Cutting Width | 54 inches (1372 mm) | 60 inches (1524 mm) | 66 Inches (1676.4) |
| Cutting Height | | (1/4 inch Increments) 1 to 6 inches (25.4-152.4 mm) | |
| Mowing Blades | | | |
| Tip Speed @ 3600 RPM | | 18,750 fpm (342.937 km/h) | |
| Length | 19 inches (482.6 mm) | 21 inches (533.4 mm) | 23 Inches (584.2 mm) |
| Thickness | | .203 | |
| Number of Blades | | Three | |

** Add unit weight, ROPS weight and applicable deck weight for total Warrior Mower weight.

PLEASE USE THIS SECTION FOR THE FOLLOWING INFORMATION

When needing replacement parts, contact your **EverRide** dealer. They will need the model and serial numbers of the mower to give you the most up-to-date parts for your equipment. Refer the dealer to the parts illustration title and the item number of the parts required.

Use only genuine **EverRide** service parts on **EverRide** equipment.

Refer to the parts illustration to assist with assembly and disassembly of the mower.

TABLE OF CONTENTS

| | |
|---|-----|
| EverRide Mower Safety Decals..... | 10 |
| Mower Deck Group..... | 60 |
| Front Wheel Assembly | 64 |
| Rear Lift Rod Assembly..... | 66 |
| Spindle Assembly | 68 |
| Handle Assembly | 70 |
| Air Filter Assembly..... | 70 |
| Control Panel Assembly | 72 |
| FULL VISION ROPS..... | 72 |
| FEMCO ROPS..... | 74 |
| Hydraulic Pump Assembly..... | 74 |
| Clutch Assembly | 76 |
| Tire & Bumper Assembly | 78 |
| Front Axle To Frame Assembly..... | 80 |
| Wheel Motor Assembly..... | 82 |
| Electric Components..... | 84 |
| Fuel Components..... | 86 |
| Hydraulic Components..... | 88 |
| Seat & Foot Plate Assembly..... | 90 |
| Deck Attachment Components..... | 92 |
| Deck Lift Components..... | 94 |
| Pump Components..... | 96 |
| Briggs & Stratton Engine Components..... | 96 |
| Engine Attach Components..... | 98 |
| 27 H.P. Kohler Engine/Exhaust Components..... | 98 |
| Motion Control Assembly..... | 100 |

EverRide reserves the right to change, modify, or eliminate from time to time, for technical or other reasons, certain or all data, specifications, or equipment of the product, or the products themselves, without any liability or obligation.

62 - MOWER DECK GROUP

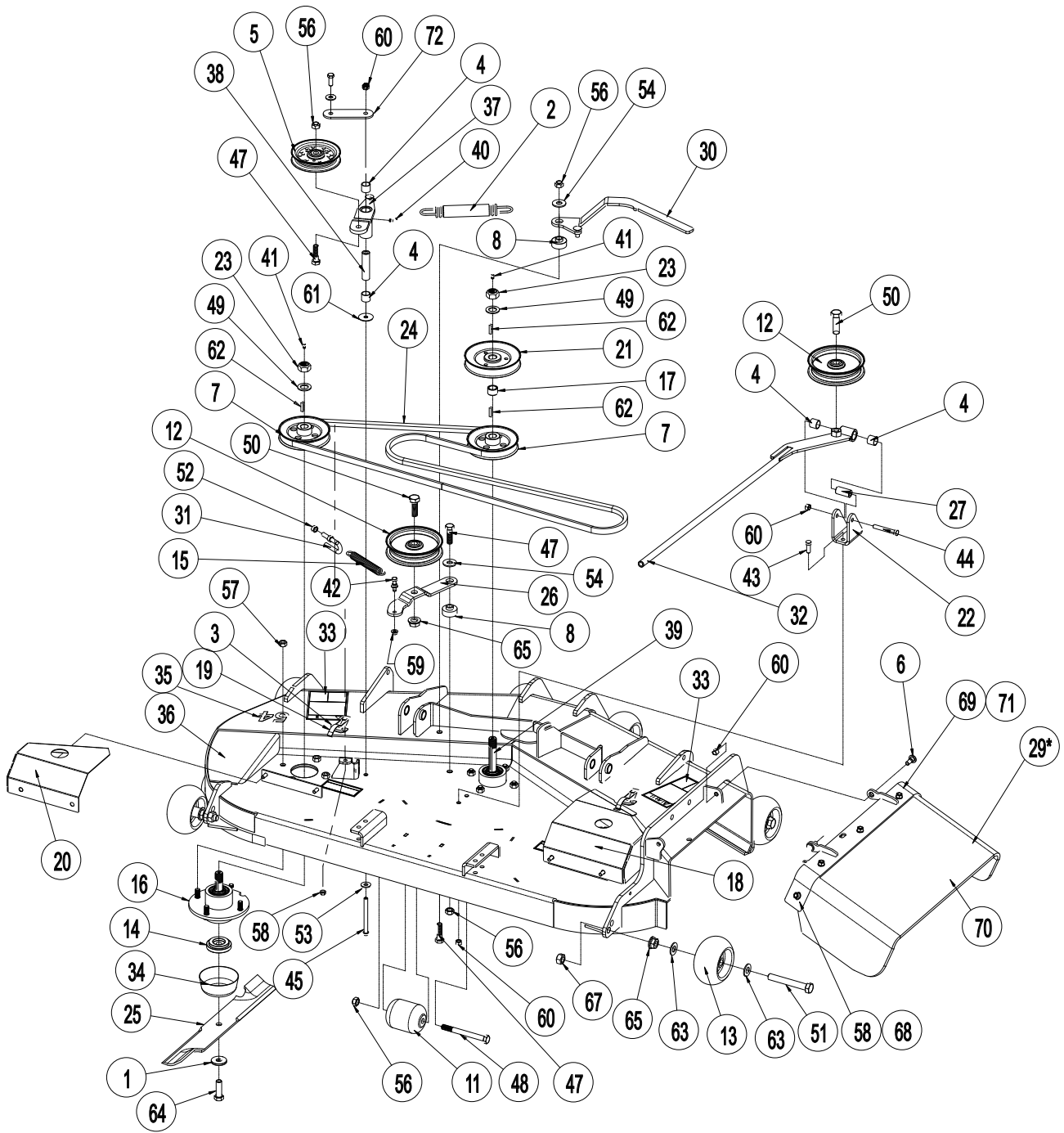

MOWER DECK GROUP - 63

| ITEM | PART NO | QTY | DESCRIPTION |
|------|---------|-----|---|
| 1 | 103906 | 3 | WASHER, M14 X M40 X M4.5 FLAT Y |
| 2 | 104657 | 1 | SPRING, EXT 1.18 X .177 X 7.50 Y |
| 3 | 104834 | 4 | RIVET, POP .188 X .375 STEEL |
| 4 | 105546 | 4 | BRG, SLV .753 X .878 X .750 |
| 5 | 112614 | 1 | PULLEY, V-BELT 5.00 X .510 |
| 6 | 135139 | 2 | BOLT, 1/2 X 1.06 X 3/8-16 SLD 5 Y |
| 7 | 181821 | 3 | PULLEY, V-BELT 5.23 X 1.0 W/KEYWAY |
| 8 | 160100 | 2 | SPACER, Ø.516 X Ø1.50 X .853 Y |
| 9 | 160169 | 2 | DECAL, WARNING - SHIELD |
| 10 | 161367 | 2 | PIN, CVS .750 X 2.75 X 2.52 Y |
| 11 | 161573 | 1 | ROLLER, Ø3.00 X 3.88 |
| 12 | 162146 | 2 | PULLEY, FLAT 5.00 X .635 W/BRG |
| 13 | 162701 | 6 | WHEEL, GAUGE - Ø5.00 X 2.76 |
| 14 | 162779 | 3 | SPACER, BLADE |
| 15 | 162801 | 1 | SPRING, EXT .750 X .125 X 4.50 Y |
| 16 | 180724 | 2 | ASSY, OUTER SPINDLE S/O |
| 17 | 181822 | 1 | SPACER, Ø.760 X Ø1.00 X .635 Y |
| 18 | 180494 | 1 | SHIELD, RH 54" & 60" BELT |
| | 181709 | 1 | SHIELD, RH 66" BELT |
| 19 | 180501 | 2 | LATCH, OVERCENTER |
| 20 | 180778 | 1 | SHIELD, LH 54" BELT |
| | 180496 | 1 | SHIELD DECK LH - 60" |
| | 181708 | 1 | SHELD DECK LH - 66" |
| 21 | 181907 | 1 | PULLEY, V-BELT 5.75X 1.0 W/KEYWAY - 54" |
| | 181823 | 1 | PULLEY, V-BELT 6.75 X 1.0 W/KEYWAY - 60" |
| | 181911 | 1 | PULLEY, V-BELT 7.21 X 1.0 W/KEYWAY - 66" |
| 22 | 181010 | 1 | PLATE, PIVOT ANCHOR BENT |
| 23 | 964024 | 3 | LOCKNUT, 3/4-16 |
| 24 | 181036 | 1 | BELT, B112 - 54" DECK |
| | 112616 | 1 | BELT, B120 - 60"DECK |
| | 181711 | 1 | BELT, 131.0 EL ARAMID - 66" DECK |
| 25 | 181042 | 3 | BLADE, 19.000 LO-LIFT - 54" DECK |
| | 181026 | 3 | BLADE, 20.940 LO-LIFT - 60" DECK |
| | 181707 | 3 | BLADE, 23.0 LO-LIFT - 66" DECK |
| 26 | 181043 | 1 | ARM, BELT TENSION 54" |
| | 181188 | 1 | ARM, BELT TENSION 60" & 66" |
| 27 | 181062 | 1 | SPANNER, EVERDRIVE |
| 28 | 181139 | 1 | BELT, B112 - KEVLAR |
| 29 | 181173 | 1 | ASSY, DISCHARGE - RUBBER * |
| 30 | 181408 | 1 | WLDT, TENSION ARM |
| 31 | 181239 | 1 | U-BOLT, RD .63 X 2.63 X 3/8-16 SP Y - 54" |
| | 181194 | 1 | U-BOLT, RD .63 X 4.50 X 3/8-16 SP Y - 60" |

* Assembly includes items 69, 70, 71 and five each of items 58 & 68.

Continued on pages 64-65

64 - MOWER DECK GROUP - Continued

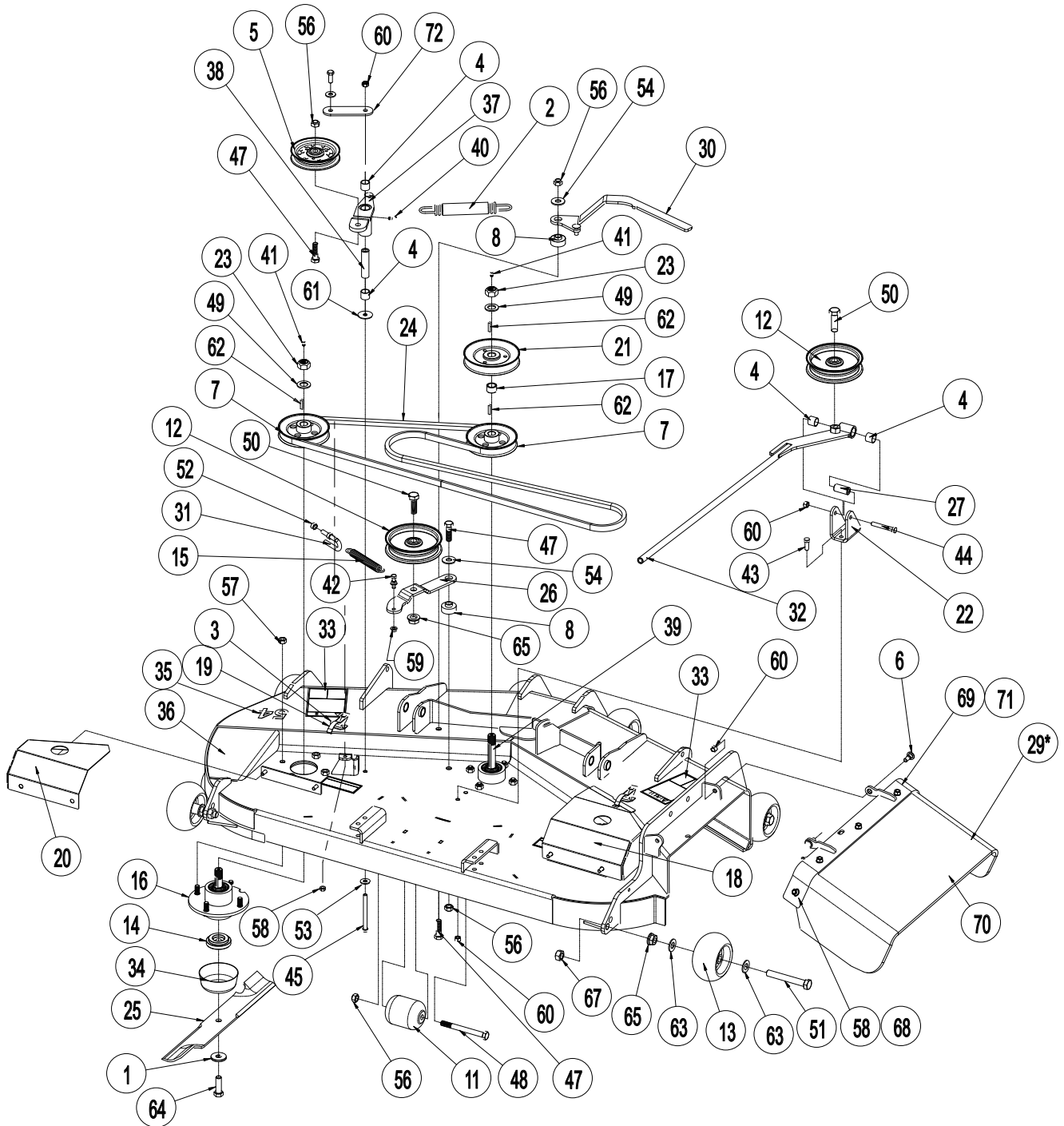

MOWER DECK GROUP - Continued - 65

| ITEM | PART NO | QTY | DESCRIPTION |
|------|---------|-----|-----------------------------------|
| 32 | 181613 | 1 | WLDT, PULLEY PIVOT |
| 33 | 181258 | 2 | DECAL, DANGER - DECK |
| 34 | 181288 | 3 | CAP, SPINDLE |
| 35 | 181367 | 1 | DECAL, DECK 54" |
| | 181368 | 1 | DECAL, DECK 60" |
| | 181719 | 1 | DECAL, DECK 66" |
| 36 | 181909 | 1 | WLDT, 54" DECK W/ DECALS S/O |
| | 181912 | 1 | WLDT, 60" DECK W/ DECALS S/O |
| | 181929 | 1 | WLDT, 66" DECK W/DECALS S/O |
| 37 | 181460 | 1 | WLDT, DECK IDLER ARM S/O |
| 38 | 191347 | 1 | TUBE, Ø.750 X Ø.438 X 3.047 |
| 39 | 181908 | 1 | ASSY, CENTER SPINDLE |
| 40 | 959994 | 1 | FTG, 1/4-28 TPR 45 GREASE ZERK |
| 41 | 959995 | 3 | FTG, 1/4-28 STRGT GREASE ZERK |
| 42 | 960024 | 1 | BOLT, 5/16-18 X 1.25 HEX 5 Y |
| 43 | 960046 | 2 | BOLT, 3/8-16 X 1.00 HEX 5 Y |
| 44 | 960052 | 1 | BOLT, 3/8-16 X 2.50 HEX 5 Y |
| 45 | 960059 | 1 | BOLT, 3/8-16 X 4.00 HEX 5 Y |
| 46 | 960082 | 2 | BOLT, 7/16-14 X 1.75 HEX 5 Y |
| 47 | 960115 | 3 | BOLT, 1/2-13 X 1.75 HEX 5 Y |
| 48 | 960128 | 1 | BOLT, 1/2-13 X 5.00 HEX 5 Y |
| 49 | 964500 | 3 | FLATWASHER, 3/4 SAE |
| 50 | 960155 | 2 | BOLT, 5/8-11 X 1.50 HEX 5 Y |
| 51 | 960167 | 6 | BOLT, 5/8-11 X 4.25 HEX 5 Y |
| 52 | 960502 | 2 | NUT, 3/8-16 STD HEX GR5 Y |
| 53 | 960702 | 2 | WASHER, .375 REG FLAT Y |
| 54 | 960704 | 2 | WASHER, .500 REG FLAT Y |
| 55 | 962018 | 2 | PIN, COT .125 X 1.25 EXTP Y |
| 56 | 964000 | 4 | LOCKNUT, 1/2-13 CROWN Y |
| 57 | 964005 | 12 | NUT, 7/16-20 HEX GR5 Y |
| 58 | 964016 | 13 | LOCKNUT, 3/8-16 WHIZ Y |
| 59 | 964019 | 2 | LOCKNUT, 5/16-18 WHIZ Y |
| 60 | 964022 | 6 | LOCKNUT, 3/8-16 CROWN Y |
| 61 | 964502 | 1 | WASHER, .375 X 1.50 X .063 FLAT Y |
| 62 | 966045 | 4 | KEY, .250 X .250 X 1.00 SQ |
| 63 | 967087 | 12 | WASHER, .625 X 1.31 X .098 FLAT Y |
| 64 | 967187 | 3 | BOLT, 9/16-12 X 1.75 HEX 8 Y |
| 65 | 967324 | 7 | LOCKNUT, 5/8-11 WHIZ Y |
| 66 | 967342 | 4 | LOCKNUT, 7/16-14 WHIZ Y |
| 67 | 967392 | 6 | LOCKNUT, 5/8-11 CROWN Y |
| 68 | 963020 | 5 | BOLT, 3/8-16 X 1 CRG 5 Y |
| 69 | 181120 | 1 | WLDT, DISCHARGE SHIELD BRACKET |
| 70 | 181129 | 1 | SHIELD, RUBBER DISHARGE |
| 71 | 181115 | 1 | PLATE, DISCHARGE SHIELD SUPPORT |
| 72 | 181926 | 1 | STRAP, BELT TENSION |

66 - FRONT WHEEL ASSEMBLY

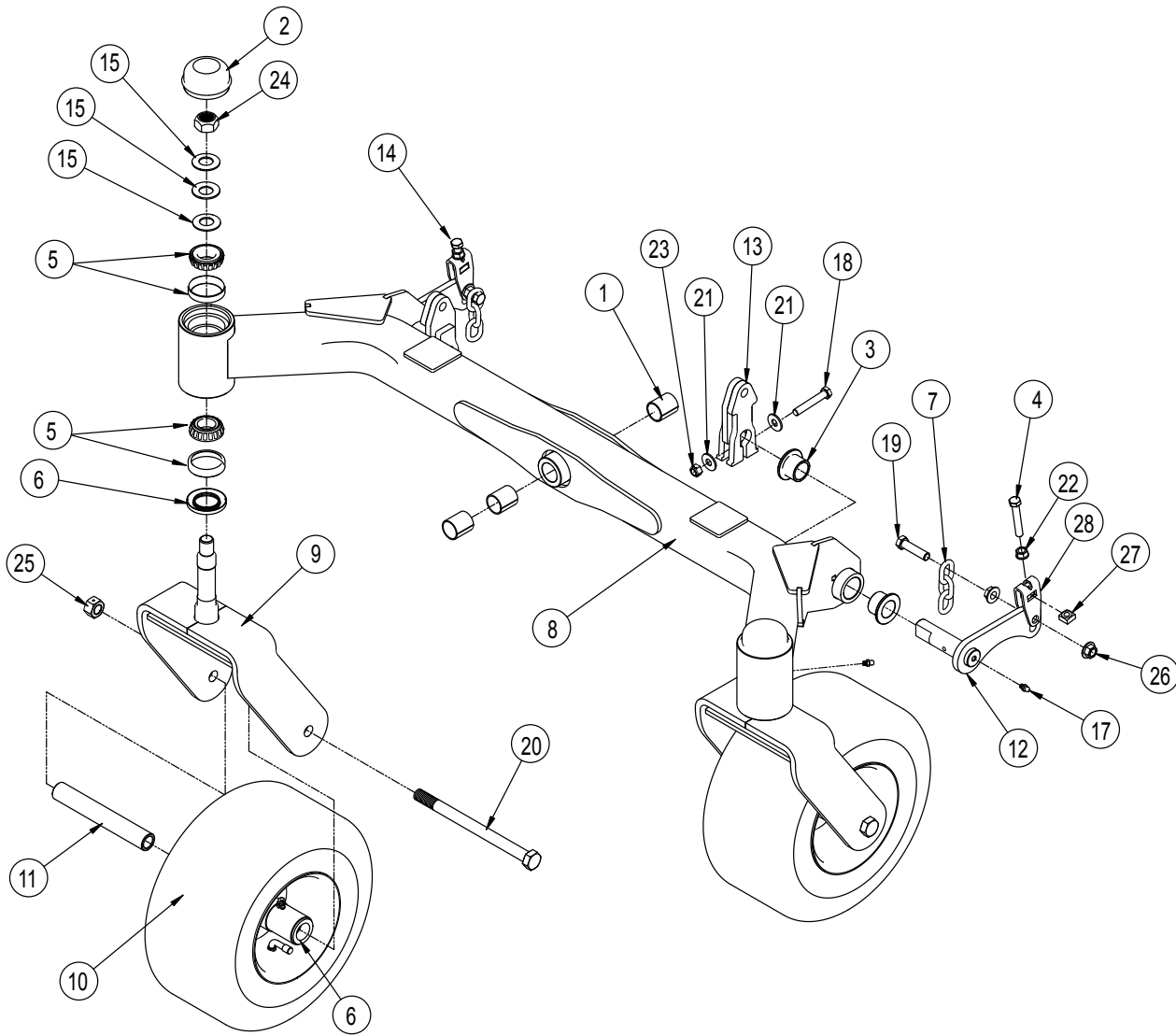

FRONT WHEEL ASSEMBLY - 67

| ITEM | PART NO | QTY | DESCRIPTION |
|------|---------|-----|--|
| 1 | 105591 | 3 | BEARING, SLV 1.00 X 1.13 X 1.25 |
| 2 | 105596 | 2 | CAP |
| 3 | 130885 | 4 | BRG, FLG 1.00X1.25X.944 |
| 4 | 967396 | 2 | BOLT, 3/8-16 X 2.25 HEX 5 |
| 5 | 180925 | 4 | KIT, SPINDLE BEARING |
| 6 | 182189 | 2 | KIT, FRONT WHEEL BEARING |
| 7 | 150109 | 2 | CHAIN - 3 LINKS |
| 8 | 180055 | 1 | FRONT AXLE WLDT |
| 9 | 181432 | 2 | WLDT, Z FRONT WHEEL FORK |
| 10 | 180256 | 2 | ASSY, TIRE & RIM - 13/6.50 X 6 |
| 11 | 180257 | 2 | TUBE, FRONT TIRE AXLE |
| 12 | 180977 | 1 | WLDT, LH FRONT PIVOT W/ZERK S/O |
| 13 | 180983 | 2 | FRONT PIVOT CLAMP WLDT |
| 14 | 181566 | 2 | ASSY, FRONT PIVOT (INCLUDES 4, 22, 27, 28) |
| 15 | 180992 | 6 | WASHER, .750 X 1.50 X .072 BLVL |
| 16 | 181174 | 2 | LINK, U-BRACKET |
| 17 | 959995 | 4 | FTG, 1/4-28 STRGT GREASE ZERK |
| 18 | 960051 | 2 | BOLT, 3/8-16 X 2.25 HEX 5 |
| 19 | 960082 | 2 | BOLT, 7/16-14 X 1 3/4 GR5 |
| 20 | 960176 | 2 | BOLT, 5/8-11 X 8.50 HEX 5 |
| 21 | 960702 | 4 | WASHER, .375 REG FLAT |
| 22 | 964016 | 2 | LOCKNUT, 3/8-16 WHIZ |
| 23 | 964022 | 2 | LOCKNUT, 3/8-16 CROWN |
| 24 | 964024 | 2 | LOCKNUT, 3/4-16 CROWN |
| 25 | 964032 | 2 | LOCKNUT, 5/8-11 CENTER |
| 26 | 967342 | 4 | LOCKNUT, 7/16-14 WHIZ |
| 27 | 967395 | 2 | NUT, 3/8-16 SQUARE |
| 28 | 181174 | 1 | WLDT, RH FRONT PIVOT W/ZERK S/O |

68 - REAR LIFT ROD ASSEMBLY

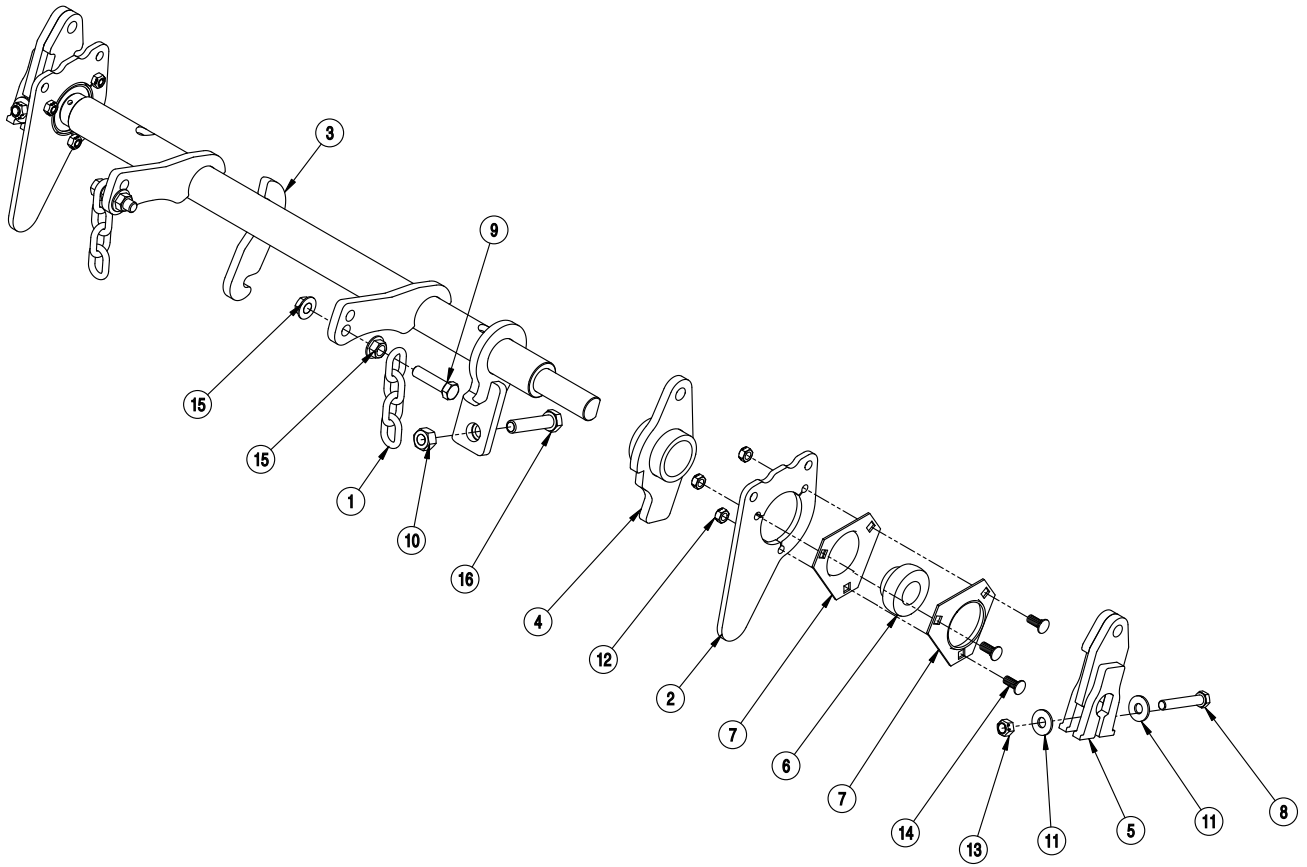

REAR LIFT ROD ASSEMBLY - 69

| ITEM | PART NO | QTY | DESCRIPTION |
|------|---------|-----|----------------------------------|
| 1 | 150110 | 2 | CHAIN, 4 LINKS 1/4" |
| 2 | 180841 | 2 | BALL BEARING PLATE |
| 3 | 180860 | 1 | CENTER LIFT WLDT |
| 4 | 180868 | 1 | WLDT, HOC ROTATION ADJUSTMENT |
| 5 | 180983 | 2 | FRONT PIVOT CLAMP WLDT |
| 6 | 251060 | 2 | BEARING |
| 7 | 251061 | 4 | FLANGE, BEARING 52MM-3T |
| 8 | 960051 | 2 | BOLT, 3/8-16 X 2.25 HEX 5 |
| 9 | 960082 | 2 | BOLT 7/16-14 X 1 3/4 GR5 |
| 10 | 960504 | 1 | NUT, 1/2-13 STD HEX GR5 |
| 11 | 960702 | 4 | WASHER, .375 REG FLAT |
| 12 | 964021 | 6 | LOCKNUT, 5/16-18 CROWN |
| 13 | 964022 | 2 | LOCKNUT, 3/8-16 CROWN |
| 14 | 967152 | 6 | BOLT, 5/16-18 X 3/4 CARR GR5 PLT |
| 15 | 967342 | 4 | LOCKNUT, 7/16-14 WHIZ |
| 16 | 967341 | 1 | BOLT, 1/2-13 X 2.25 SPEC 5 |

70 - SPINDLE ASSEMBLY

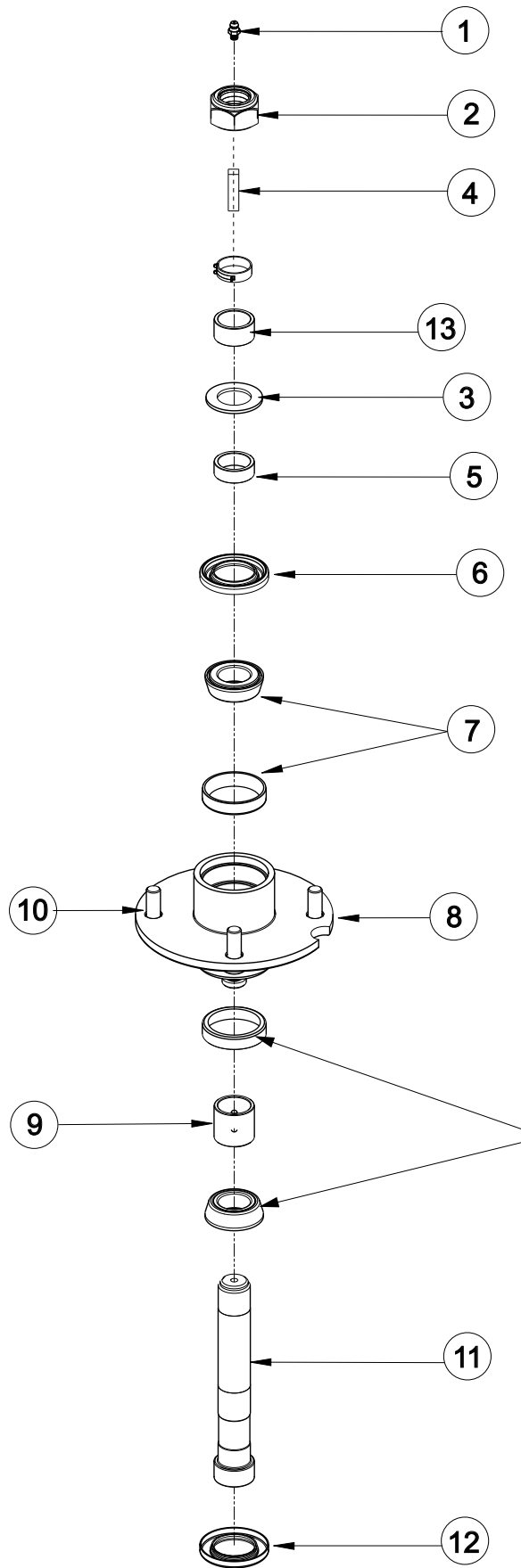

SPINDLE ASSEMBLY - 71

| ITEM | PART NO | QTY | DESCRIPTION |
|------|---------|-----|---------------------------------|
| * | 181917 | 2 | SPINDLE ASSY. |
| * | 181910 | 1 | SPINDLE ASSY., CENTER |
| * | 180925 | 1 | SPINDLE BEARING KIT S/O* |
| 1 | 959995 | 1 | FITTING, GREASE 1/4-28 STRAIGHT |
| 2 | 181818 | 1 | LOCKNUT, 1" |
| 3 | 960711 | 1 | FLATWASHER, 3/4 SAE |
| 4 | 966045 | 1 | KEY, 1/4 SQUARE X 1 ** |
| 5 | 145557 | 1 | SPACER, SEAL |
| 6 | 145551 | 1 | SEAL, UPPER |
| 7 | 145555 | 2 | BEARING ASSY, CUP & CONE |
| 8 | 160001 | 1 | HOUSING, SPINDLE |
| 9 | 160116 | 1 | PRE-LOAD SPACER, .606 |
| 10 | 145561 | 4 | STUD, SPECIAL 7/16-20 |
| 11 | 180334 | 1 | SHAFT, SPINDLE |
| 11 | 180857 | 1 | SHAFT, SPINDLE CENTER SPINDLE |
| 12 | 145552 | 1 | SEAL, LOWER |
| 13 | 181822 | 1 | SPACER, 1.01 X 1.25 X .635Y |

* Includes items 6, 7, 9 & 12

** Spindle Assy. does not include item 4

72 - HANDLE ASSEMBLY/AIR FILTER ASSEMBLY

HANDLE ASSEMBLY

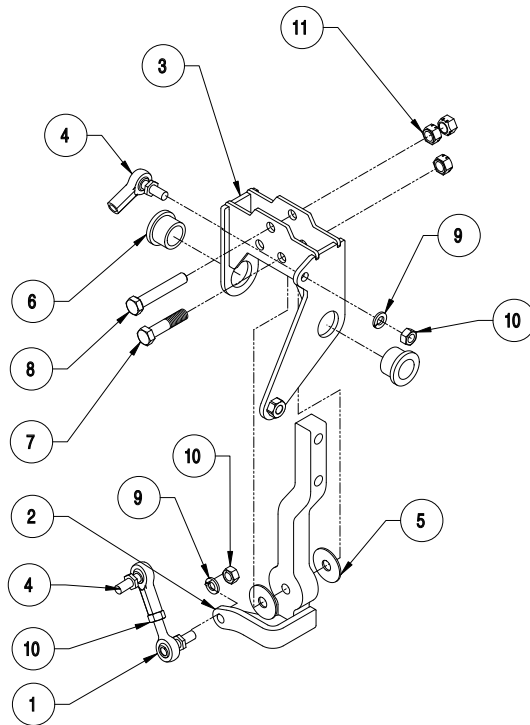

AIR FILTER ASSEMBLY

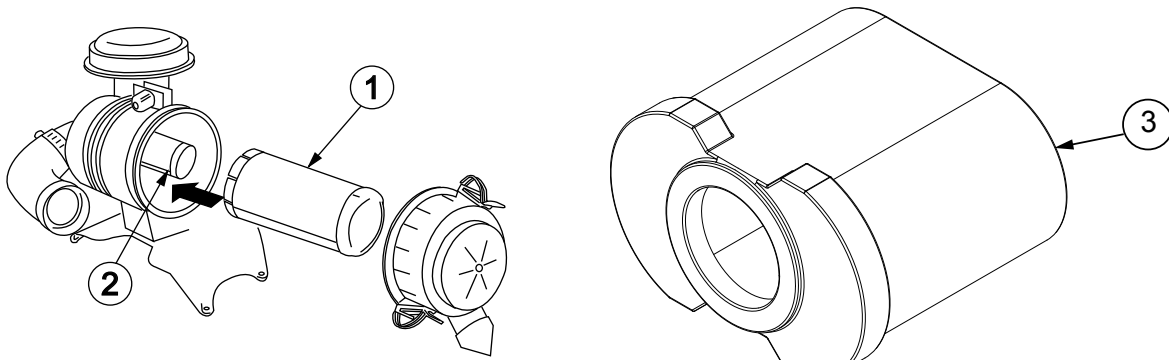

Kawasaki/Kohler

Brigg's & Stratton Cannister

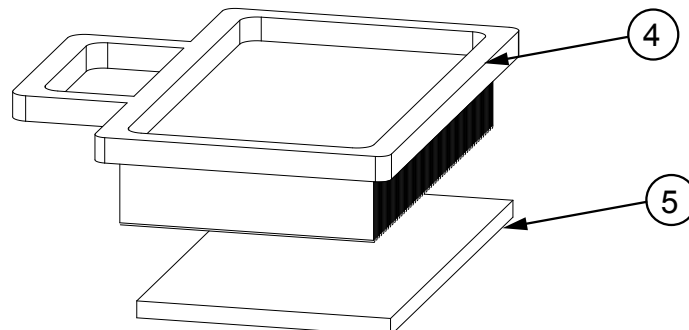

Brigg's & Stratton Cartridge Air Filter

HANDLE ASSEMBLY/AIR FILTER ASSEMBLY - 73

HANDLE ASSEMBLY

| ITEM | PART NO | QTY | DESCRIPTION |
|------|---------|-----|--------------------------------|
| 1 | 180249 | 1 | BALL JOINT RH 5/16 MALE W/ STD |
| 2 | 180544 | 1 | BAR WLDT RH STEERING |
| | 180532 | 1 | BAR WLDT LH STEERING |
| 3 | 180545 | 1 | HANDLE CONTROL WLDT, RH |
| | 180536 | 1 | HANDLE CONTROL WLDT, LH |
| 4 | 180606 | 2 | BALL JOINT, RH 5/16 FMAL W/STD |
| 5 | 180961 | 2 | NYLON WASHER, 1.27OD X .400 ID |
| 6 | 252126 | 2 | BUSHING, .750 X 1.00 X .750 |
| 7 | 960049 | 1 | BOLT, 3/8-16 X 1.75 HEX 5 |
| 8 | 960051 | 1 | BOLT, 3/8-16 X 2.25 HEX 5 |
| 9 | 960601 | 2 | WASHER, .313 MED SPRG LOCK |
| 10 | 964003 | 3 | NUT, 5/16-24 STD HEX GR5 |
| 11 | 964022 | 3 | LOCKNUT, 3/8-16 CROWN |

AIR FILTER ASSEMBLY

| ITEM | PART NO | QTY | DESCRIPTION |
|------|---------|-----|------------------------------------|
| 1 | 181071 | 1 | FILTER, PRIMARY AIR |
| 2 | 181072 | 1 | FILTER, SECONDARY AIR |
| 3 | 181838 | 1 | FILTER, B & S ELS CARTRIDGE |
| 4 | 181571 | 1 | FILTER, B & S HI PROFILE CARTRIDGE |
| 5 | 191632 | 1 | FILTER, B & S PRE-CLEANER |

74 - CONTROL PANEL ASSEMBLY/FULL VISION ROPS

CONTROL PANEL ASSEMBLY

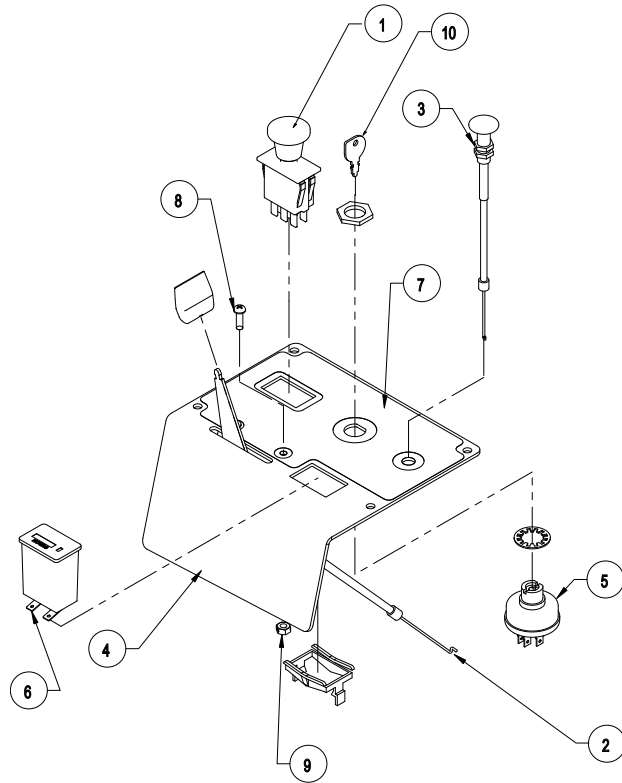

FULL VISION ROPS

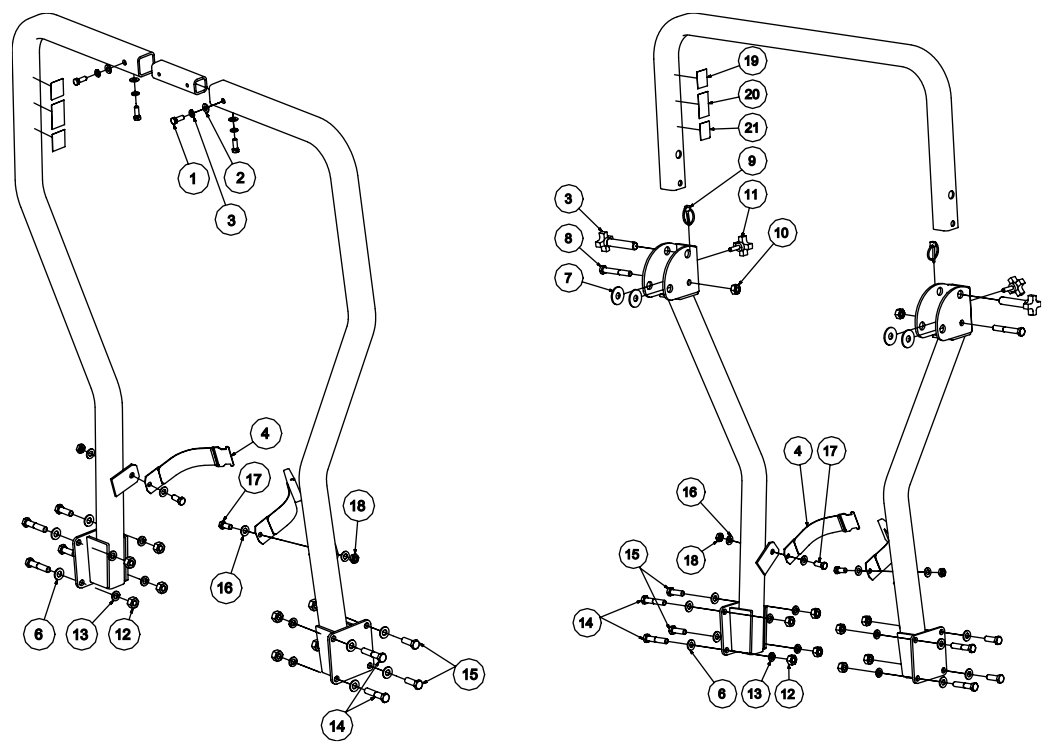

CONTROL PANEL ASSEMBLY/FULL VISION ROPS- 75

CONTROL PANEL ASSEMBLY

| ITEM | PART NO | QTY | DESCRIPTION |
|------|---------|-----|---|
| 1 | 136574 | 1 | SWITCH, PTO ENGAGEMENT |
| 2 | 181296 | 1 | THROTTLE CABLE |
| 3 | 180273 | 1 | CHOKE CABLE - 25 H.P. KAWASAKI GEN 2-3 BRIGGS & STRATTON |
| | 181143 | 1 | CHOKE CABLE - 27 H.P. KOHLER |
| 4 | 181470 | 1 | CONTROL PANEL S/O |
| 5 | 180620 | 1 | KEY SWITCH - 3 POSITION W/KEY |
| 6 | 180799 | 1 | HOUR METER; QUARTZ |
| 7 | 181441 | 1 | DECAL, CONTROL PANEL |
| 8 | 967340 | 4 | SCREW PAN HD PHL #10-24x5/8 |
| 9 | 964028 | 4 | LOCKNUT, 10-24 CENTER Y |
| 10 | 105684 | 1 | KEY, IGNITION S/O |

FULL VISION ROPS

| ITEM | PART NO | QTY | DESCRIPTION |
|------|---------|-----|----------------------------------|
| 1 | 960046 | 4 | BOLT, 3/8-16 X 1.00 HEX |
| 2 | 960702 | 4 | WASHER, .375 REG FLAT |
| 3 | 181119 | 2 | PIN ASSEMBLY S/O |
| 4 | 181092 | 1 | ASSEMBLY, SEAT BELT |
| 5 | 960602 | 4 | WASHER, .375 SPRING LOCK |
| 6 | 960704 | 8 | WASHER, .500 REG FLAT |
| 7 | 181090 | 4 | WASHER, UHMW.56ID X1.25OD X.20TH |
| 8 | 960122 | 2 | BOLT, 1/2-13 X 3.5 HEX |
| 9 | 967212 | 2 | PIN, LNC .188X1.25 |
| 10 | 967106 | 2 | LOCKNUT, 1/2-13 CENTER |
| 11 | 181118 | 2 | KNOB W/STUD, 3/8-16 X 1.5 S/O |
| 12 | 960504 | 8 | NUT, 1/2-13 STD HEX GR5 |
| 13 | 960604 | 8 | WASHER, .500 MED SPRG LOCK |
| 14 | 960118 | 4 | BOLT, 1/2-13X2.50 HEX 5 |
| 15 | 960114 | 4 | BOLT, 1/2-13X1.50 HEX 5 |
| 16 | 960703 | 4 | WASHER, .438 REG FLAT |
| 17 | 960529 | 2 | BOLT, 7/16-20X1.00 HEX 5 |
| 18 | 960528 | 2 | LOCKNUT, 7/16-20 CENTER |
| 19 | N/A | 1 | ROPS DECAL |
| 20 | N/A | 1 | SAFETY DECAL |
| 21 | N/A | 1 | SAFETY DECAL/SEAT BELT |

NOTE: Use grade 5 or better replacement hardware on the ROPS.

76 - FEMCO ROPS/HYDRAULIC PUMP ASSEMBLY

FEMCO ROPS

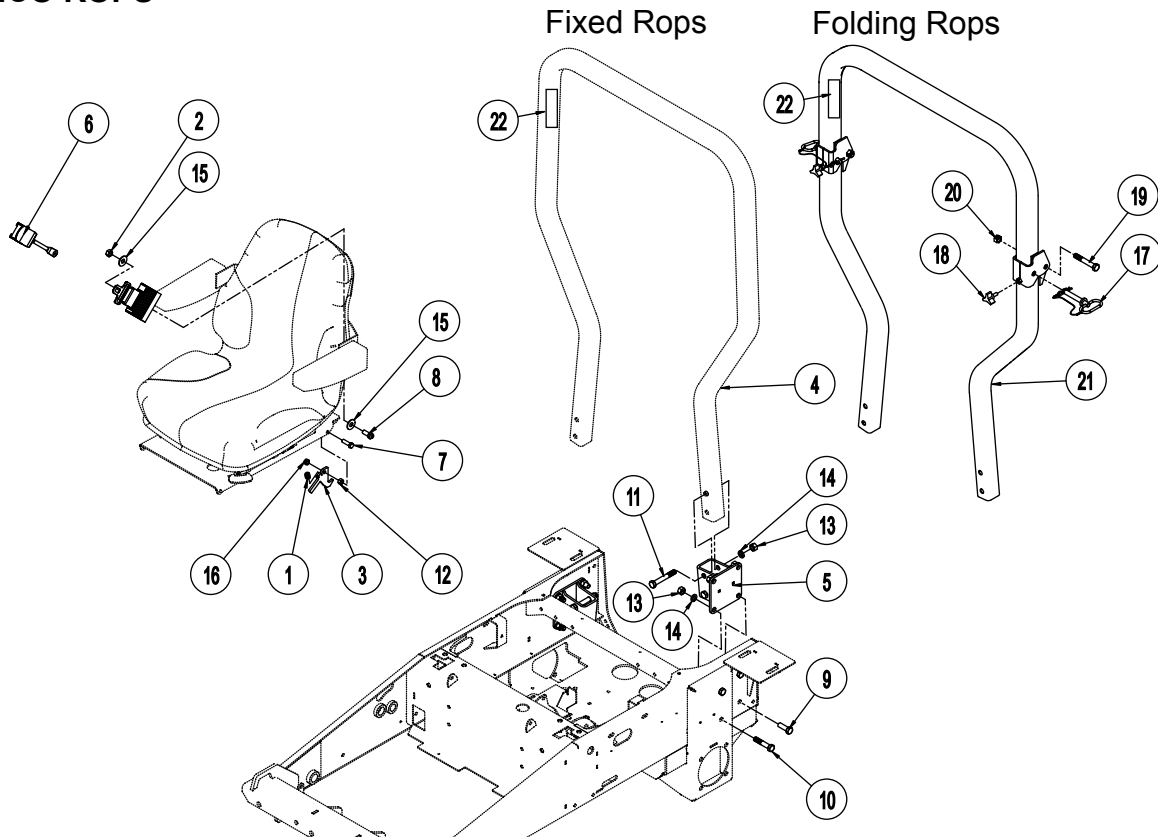

HYDRAULIC PUMP ASSEMBLY

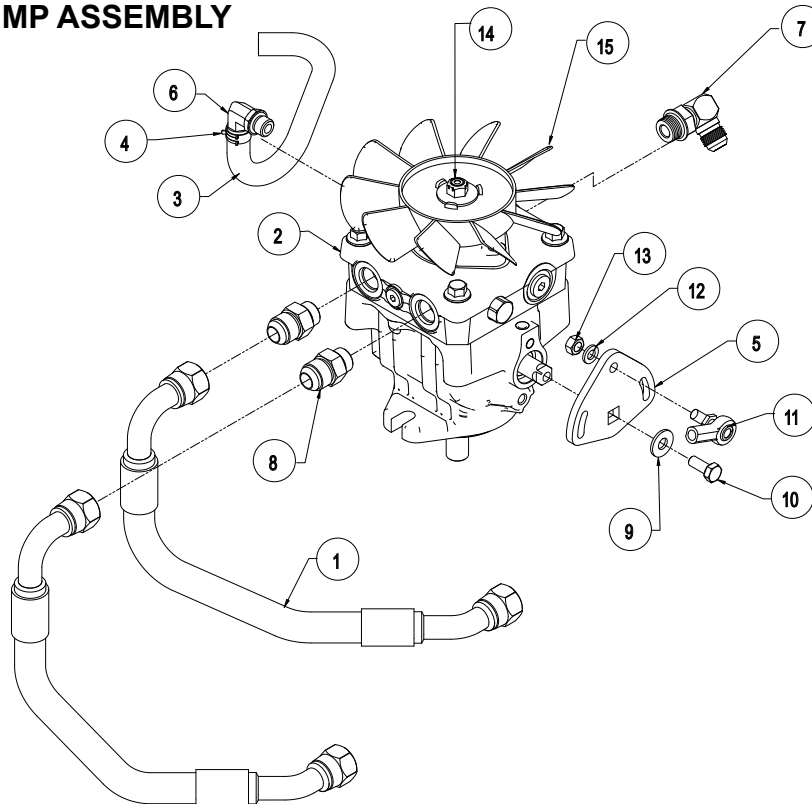

FEMCO ROPS/ HYDRAULIC PUMP ASSEMBLY - 77

| ITEM | PART NO | QTY | DESCRIPTION |
|------|---------|-----|----------------------------------|
| 1 | 160176 | 1 | SPRING, COM .600 X .059 X .875 Y |
| 2 | 964025 | 2 | LOCKNUT, 7/16-14 CROWN Y |
| 3 | 181514 | 1 | LATCH, SEAT |
| 4 | 181593 | 1 | ROPS ASSY, FEMCO FIXED WARRIOR |
| 5 | 181561 | 2 | WLDT, ROPS MOUNT |
| 6 | 181572 | 1 | ASSY, SEAT BELT |
| 7 | 960047 | 1 | BOLT, 3/8-16 X 1.25 HEX 5 Y |
| 8 | 960079 | 2 | BOLT, 7/16-14 X 1.00 HEX 5 Y |
| 9 | 960114 | 4 | BOLT, 1/2-13 X 1.50 HEX 5 Y |
| 10 | 960118 | 4 | BOLT, 1/2-13 X 2.50 HEX 5 Y |
| 11 | 960122 | 4 | BOLT, 1/2-13 X 3.50 HEX 5 Y |
| 12 | 960502 | 1 | NUT, 3/8-16 STD HEX GR5 Y |
| 13 | 960504 | 12 | NUT, 1/2-13 STD HEX GR5 Y |
| 14 | 960604 | 12 | WASHER, .500 MED SPRG LOCK Y |
| 15 | 960703 | 4 | WASHER, .438 REG FLAT Y |
| 16 | 964022 | 1 | LOCKNUT, 3/8-16 CROWN Y |
| 17 | 181591 | 2 | ASSY, FOLDING ROPS LOCK PIN S/O |
| 18 | 181592 | 2 | KNOB, STAR S/O |
| 19 | 960121 | 2 | BOLT, 1/2-13 X 3.50 HEX 5 Y |
| 20 | 967106 | 2 | LOCKNUT, 1/2-13 CENTER |
| 21 | 181594 | 1 | ROPS ASSY, FEMCO FOLDING WARRIOR |
| 22 | 181788 | 1 | DECAL, FEMCO DANGER |

| ITEM | PART NO | QTY | DESCRIPTION |
|------|---------|-----|------------------------------------|
| 1 | 180652 | 2 | HOSE - HYD 5/8 X 18.75 |
| 2 | 180831 | 1 | PUMP, LH BDP16A W/FAN |
| | 180832 | 1 | PUMP, RH BDP16A W/FAN |
| N/I | 181065 | 1 | KIT, PUMP SEAL |
| 3 | 180935 | 1 | HOSE, 3/8 X 12.5 LONG |
| 4 | 180947 | 1 | CLAMP, .690 OD HOSE PINCH |
| 5 | 180955 | 1 | PLATE, PUMP CONTROL ARM |
| 6 | 222151 | 1 | FTG, 9/16 MOR X 3/8 HOSE 90° |
| 7 | 230668 | 1 | FTG - HYD ELBOW 3/4 O-RING, 3/4JIC |
| 8 | 313290 | 2 | ADAPTER 3/4-16MORX7/8-14 JIC |
| 9 | 960701 | 1 | WASHER, .313 REG FLAT |
| 10 | 961284 | 1 | BOLT, M8 X 1.25 X 20 HEX 8.8 |
| 11 | 180982 | 1 | BALL JOINT, LH 5/16 FMAL W/STD |
| 12 | 960601 | 1 | WASHER, .313 MED SPRG LOCK |
| 13 | 964003 | 1 | NUT, 5/16-24 STD HEX GR5 |
| 14 | 964066 | 1 | LOCKNUT, 3/8-24 CROWN |
| 15 | 180993 | 1 | FAN, BDP16 PLASTIC COOLER |

NOTE: Quantities listed are per side.

78 - CLUTCH ASSEMBLY

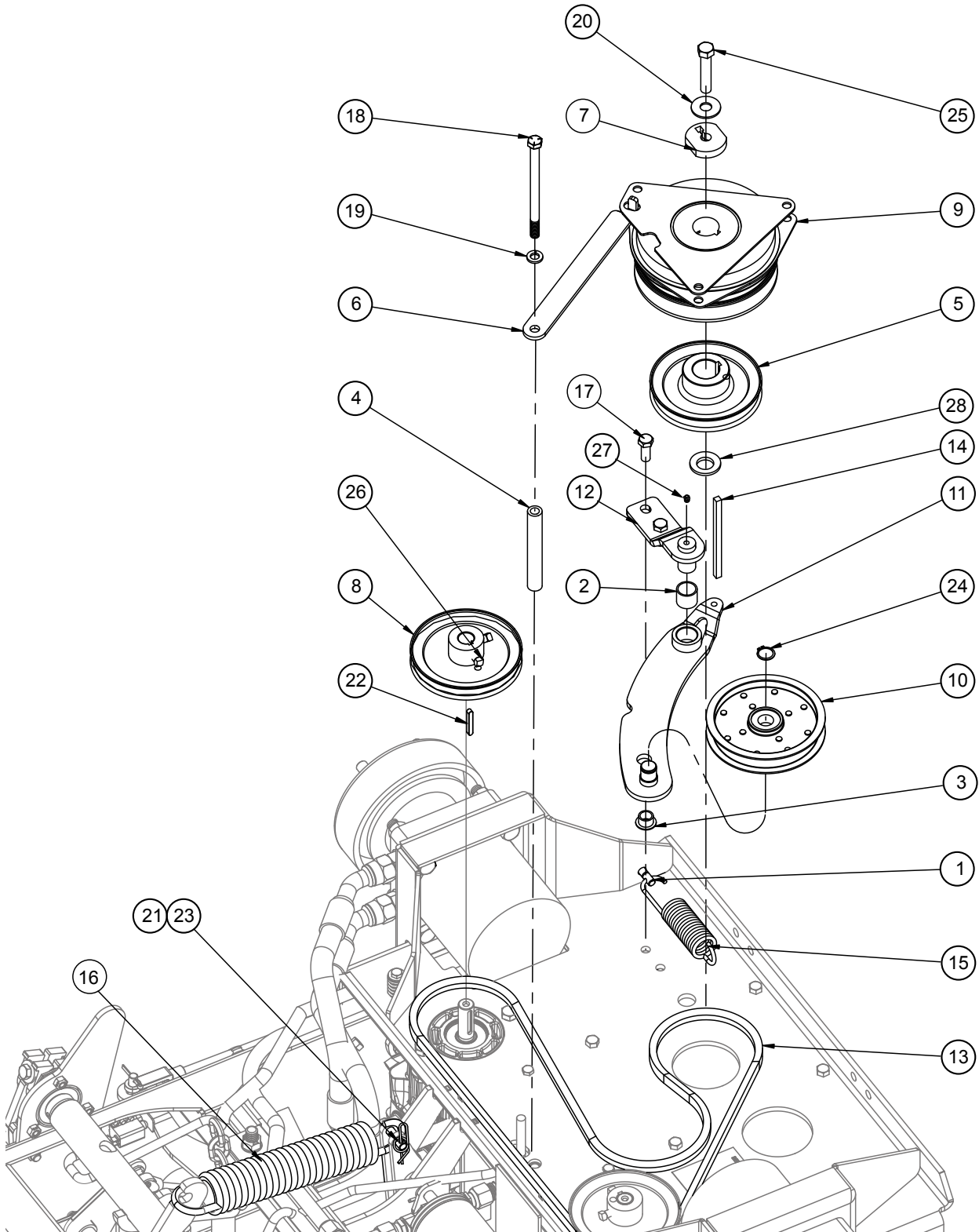

| ITEM | PART NO | QTY | DESCRIPTION |
|------|---------|-----|--|
| 1 | 104024 | 1 | ROD - THREADED ADJUSTMENT |
| 2 | 105546 | 3 | BEARING, SLV .750 X .875 X .75 |
| 3 | 180354 | 7 | BEARING SHLD 1/2" |
| 4 | 180591 | 1 | SPACER, .63 X .385X4.50 CLUTCH |
| 5 | 181106 | 1 | PULLEY, V-BELT 4.78PD X 1.125 - USE WITH EZBR2660S, EZKH2766S, EZGC5460 GRASS COLLECTOR |
| | 180641 | 1 | PULLEY, V-BELT 4.78PD X 1.125 - USE WITH ALL OTHER MODELS |
| 6 | 180670 | 1 | CLUTCH STOP |
| 7 | 191203 | 1 | WASHER, CLUTCH - W/ KEY HOLE |
| 8 | 180836 | 2 | PULLEY - PUMPS 4.78 PD 17MM |
| 9 | 180923 | 1 | CLUTCH, ELECT - OGURA, GT3.5 |
| 10 | 180927 | 1 | Z PUMP BELT IDLER |
| 11 | 180928 | 1 | Z PUMP BELT IDLER ARM WLDT |
| 12 | 181237 | 1 | Z PUMP IDLER RETAINER WLDT W/ZERK S/O |
| 13 | 181105 | 1 | BELT, HA 62.2 EL (Hydraulic Pump) USE WITH EZBR2660S, EZKH2766S, EZGC5460 GRASS COLLECTOR |
| | 181727 | 1 | BELT, HA 64.2 EL (Hydraulic Pump) USE WITH ALL OTHER MODELS |
| 14 | 180962 | 1 | KEY, .25 X .25 X 4.62 SQ |
| 15 | 180999 | 1 | SPRING, EXT 1.188 X .162 X 4.25 |
| 16 | 250083 | 1 | SPRING, EXT 1.90 X .306 X 10.75 |
| 17 | 960046 | 25 | BOLT, 3/8-16 X 1.00 HEX 5 |
| 18 | 960063 | 3 | BOLT, 3/8-16 X 5.50 HEX 5 |
| 19 | 960602 | 1 | WASHER, .375 MED SPRG LOCK |
| 20 | 960703 | 1 | WASHER, .438 REG FLAT |
| 21 | 967353 | 1 | RING, RUE .375 X .054 X 1.254 |
| 22 | 966053 | 2 | KEY, M5 X M5 X M36 RE |
| 23 | 967013 | 4 | PIN, CVS .375 X 1.38 X 1.14 |
| 24 | 967018 | 9 | SNAP RING, .621 X .035 EXT |
| 25 | 967337 | 1 | BOLT, 7/16-20 X 2.25 HEX 5 |
| 26 | 967343 | 4 | SET SCREW, SQ HD 5/16-18 PL |
| 27 | 959995 | 1 | FTG, 1/4-28 STRAIGHT GREASE |
| 28 | 161074 | 1 | BUSHING, MACH. 1.13X1.75X.075 (KOHLE & BRIGGS ONLY) |

80 - TIRE & BUMPER ASSEMBLY

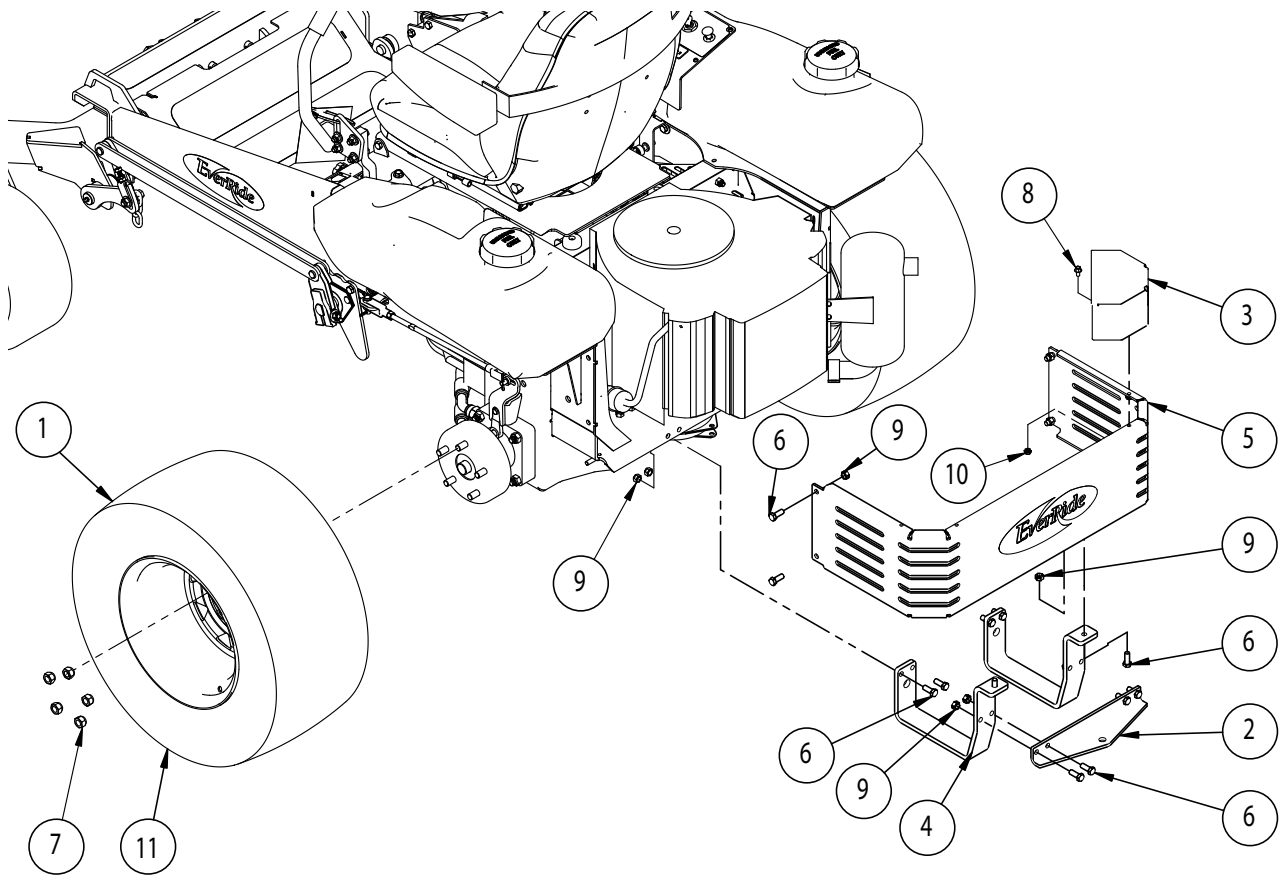

TIRE & BUMPER ASSEMBLY - 81

| ITEM | PART NO | QTY | DESCRIPTION |
|------|---------|-----|---------------------------------------|
| 1 | 180235 | 2 | ASSY, TIRE & RIM - 24/12 X 12 - TURF |
| | 181342 | 2 | RIM, 12 X 8.5 S/O |
| 2 | 180604 | 1 | REAR SUPPORT |
| 3 | 180629 | 1 | MUFFLER COVER |
| 4 | 180721 | 2 | BENT ARM, HITCH |
| 5 | 181051 | 1 | BUMPER PLATE W/DECALS S/O |
| 6 | 960046 | 25 | BOLT, 3/8-16 X 1.00 HEX 5 |
| 7 | 960526 | 10 | NUT, 1/2-20 LUG C |
| 8 | 963000 | 4 | BOLT, 1/4-20 X .500 WSH 5 |
| 9 | 964022 | 44 | LOCKNUT, 3/8-16 CROWN |
| 10 | 964040 | 8 | LOCKNUT, 1/4-20 WHIZ |
| 11 | 180924 | 2 | TIRE W/O RIM, 24 x 12 x 12 S/O - TURF |
| | 181330 | 2 | TIRE W/O RIM, 24 X 12 X 12 AT101 |

82 - FRONT AXLE TO FRAME ASSEMBLY

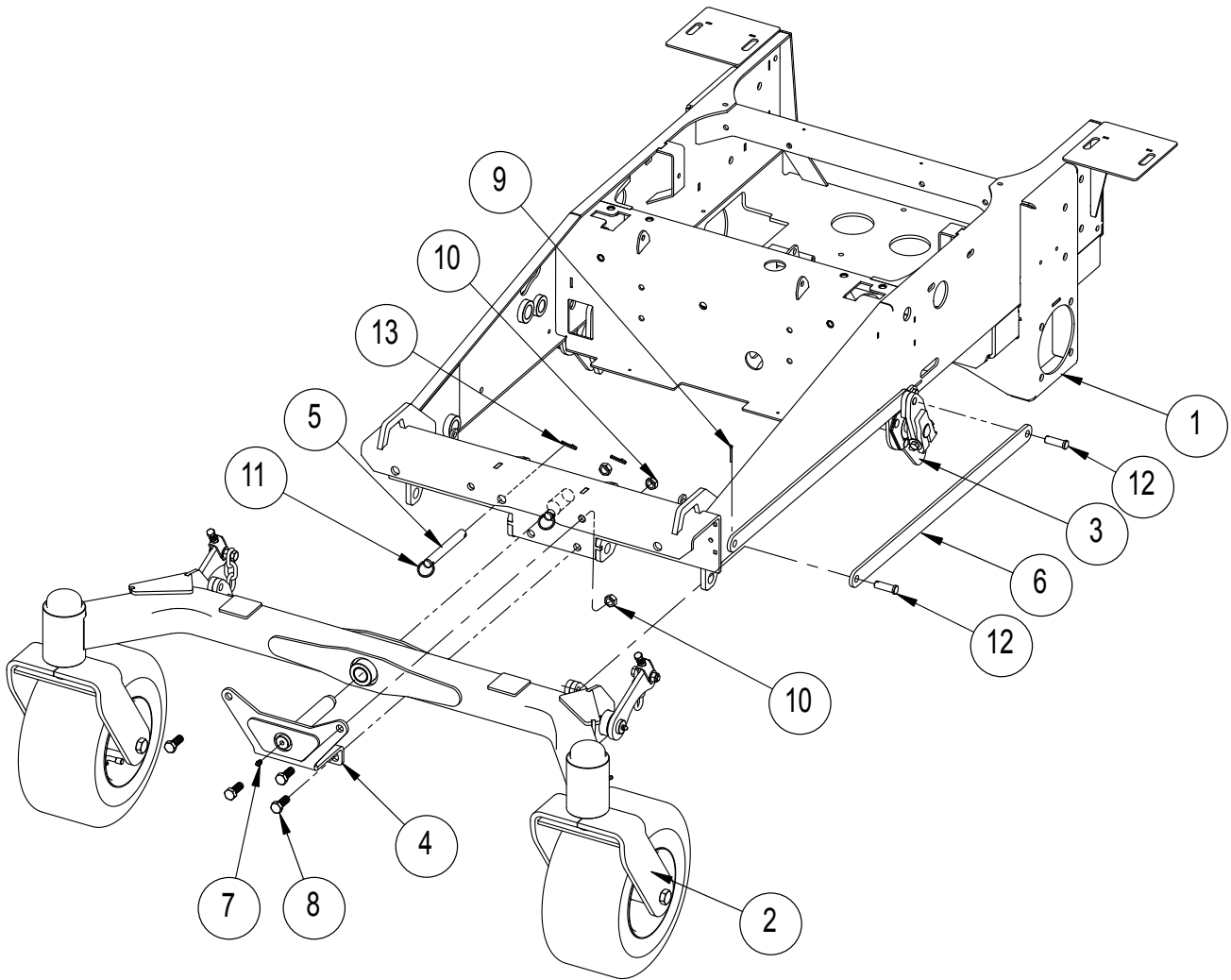

FRONT AXLE TO FRAME ASSEMBLY - 83

| ITEM | PART NO | QTY | DESCRIPTION |
|------|---------|-----|----------------------------------|
| 1 | 181429 | 1 | UNIBODY WLDT W/DECALS S/O |
| 2 | 180046 | 1 | FRONT AXLE FRAME ASSY |
| 3 | 180085 | 1 | REAR LIFT ROD ASSY |
| 4 | 181364 | 1 | FRONT AXLE BRKT W/ZERK S/O |
| 5 | 180830 | 2 | PIN, MFG .625 X 5.00 X 4.38 XDRL |
| 6 | 180898 | 4 | CONNECTOR LINK |
| 7 | 959995 | 1 | FTG, 1/4-28 STRGT GREASE ZERK |
| 8 | 960113 | 4 | BOLT, 1/2-13 X 1.25 HEX 5 |
| 9 | 967354 | 2 | RING, RUE .500 X .062 X 1.42 |
| 10 | 964000 | 4 | LOCKNUT, 1/2-13 CROWN |
| 11 | 967057 | 4 | RING, WIRE - .080 X 1.25 |
| 12 | 967196 | 2 | PIN, CVS .500 X 1.50 X 1.27 |
| 13 | 967356 | 2 | RING, RUE .625 x .072 x 1.690 |

84 - WHEEL MOTOR ASSEMBLY

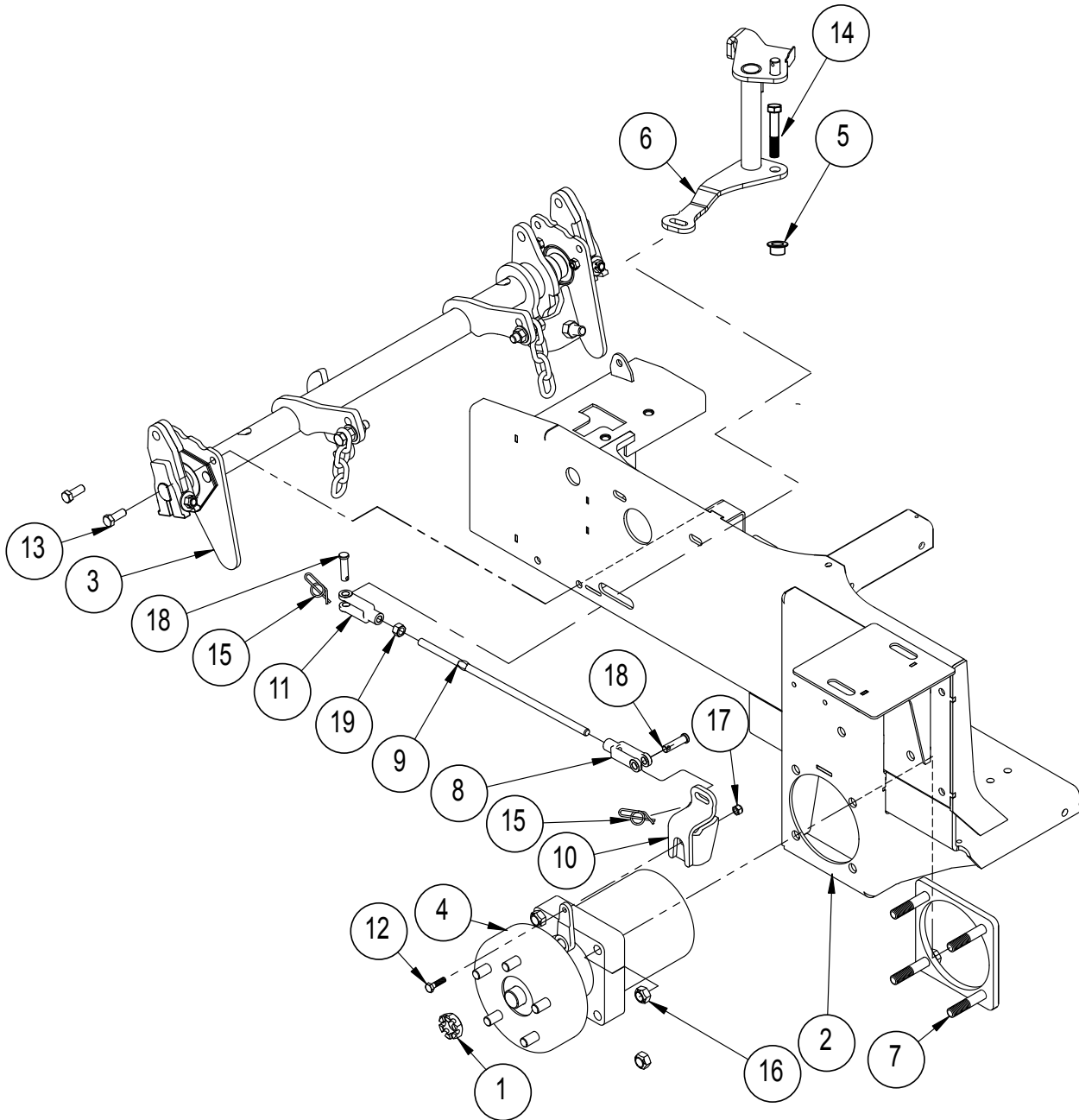

WHEEL MOTOR ASSEMBLY - 85

| ITEM | PART NO | QTY | DESCRIPTION |
|------|---------|-----|--|
| 1 | 191625 | 2 | NUT, HUB RETAINING PARKER WHEEL MOTOR |
| | 181513 | 2 | NUT, HUB RETAINING HYDRO-GEAR WHEEL MOTOR |
| 2 | 181259 | 1 | UNIBODY WLDT S/O W/DECALS |
| 3 | 180085 | 1 | REAR LIFT ROD ASSY |
| 4 | 180236 | 1 | MOTOR, LH WHEEL PARKER |
| | 181513 | 1 | MOTOR, LH WHEEL HYDRO-GEAR |
| N/I | 180237 | 1 | MOTOR, RH WHEEL PARKER |
| | 181512 | 1 | MOTOR, RH WHEEL - HYDRO-GEAR |
| 5 | 180354 | 2 | BEARING SHLD 1/2" |
| 6 | 181444 | 1 | PARK BRAKE CONTROL ARM LH |
| N/I | 181443 | 1 | PARK BRAKE CONTROL ARM RH |
| 7 | 180880 | 2 | WLDT, BOLT PLATE - PARKER WHEEL MOTOR |
| | 191509 | 2 | WLDT, BOLT PLATE - HYDRO-GEAR WHEEL MOTOR |
| 8 | 180968 | 2 | YOKE, 3/8-24 LH ADJUSTABLE |
| 9 | 180981 | 2 | ROD, STRAIGHT PARK BRAKE CONTROL |
| 10 | 180991 | 2 | WLDT, BRAKE ARM EXT - PARKER WHEEL MOTOR |
| | 181517 | 2 | WLDT, BRAKE ARM EXT - HYDRO-GEAR WHEEL MOTOR |
| 11 | 251907 | 2 | YOKE, 3/8-24 RH ADJUSTABLE |
| 12 | 960002 | 2 | BOLT, 1/4-20 X 1.00 HEX 5 |
| 13 | 960046 | 4 | BOLT, 3/8-16 X 1.00 HEX 5 |
| 14 | 960119 | 2 | BOLT, 1/2-13 X 2.75 G5 |
| 15 | 967353 | 4 | RING, RUE .375 X .054 X 1.254 |
| 16 | 960504 | 8 | NUT, 1/2-13 STD HEX G5 |
| 17 | 964048 | 2 | LOCKNUT, 1/4-20 NYLOC |
| 18 | 967013 | 4 | PIN, CVS .375 X 1.38 X 1.14 |
| 19 | 967054 | 2 | NUT, 3/8-16 STD HEX GR 5 |

86 - ELECTRICAL COMPONENTS

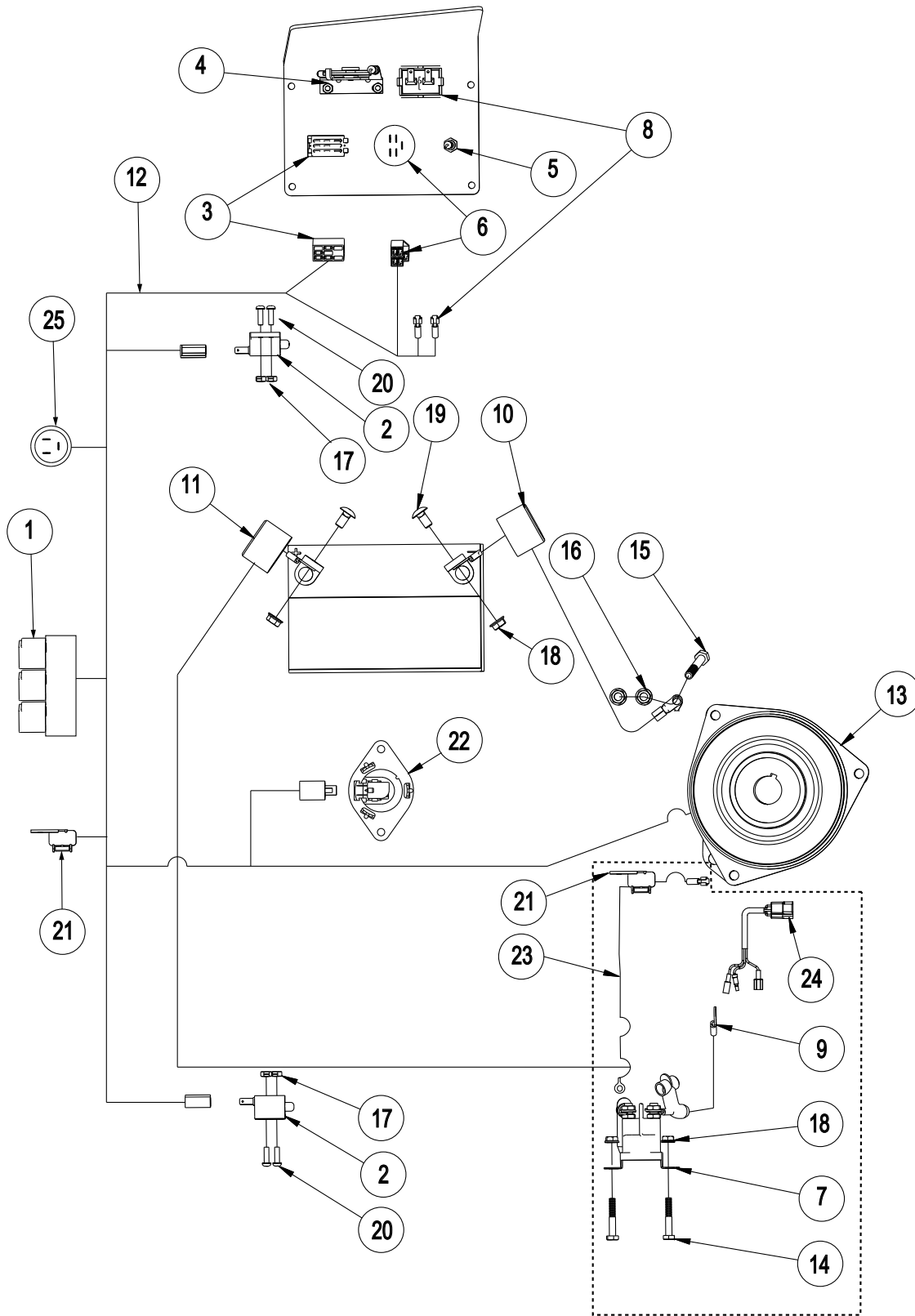

25 H.P. Kawasaki Only

ELECTRIC COMPONENTS - 87

| ITEM | PART NO | QTY | DESCRIPTION |
|------|---------|-----|---|
| 1 | 102770 | 3 | RELAY, ISO MINI ELEC. |
| 2 | 191256 | 2 | SWITCH, PLUNGER |
| 3 | 136574 | 1 | SWITCH, PTO ENGAGEMENT |
| 4 | 181296 | 1 | THROTTLE CABLE |
| 5 | 180273 | 1 | CHOKE CABLE - 25 H.P. KAWASAKI |
| | 181143 | 1 | CHOKE CABLE - 27 H.P. KOHLER |
| 6 | 180620 | 1 | KEY SWITCH - 3 POSITION |
| 7 | 180640 | 1 | SOLENOID, 12 V STARTER |
| 8 | 180799 | 1 | HOUR METER; QUARTZ |
| 9 | 180842 | 1 | STARTER CABLE - 12" - KAWASAKI |
| 10 | 180843 | 1 | BATTERY GROUND CABLE - 20" |
| 11 | 180844 | 1 | BATTERY POSITIVE CABLE - 42" - KAWASAKI |
| | 181148 | 1 | BATTERY POSITIVE CABLE - 48" - KOHLER |
| 12 | 181442 | 1 | WIRE HARNESS |
| 13 | 180923 | 1 | CLUTCH, ELECT - OGURA, GT3 |
| 14 | 960004 | 2 | BOLT, 1/4-20 X 1.5 G5 |
| 15 | 960027 | 1 | BOLT, 5/16-18 X 2.00 HEX G5 |
| 16 | 964019 | 2 | LOCKNUT, 5/16-18 WHIZ |
| 17 | 130923 | 4 | LOCKNUT, 10-24 KEPS |
| 18 | 964040 | 4 | LOCKNUT, 1/4-20 WHIZ |
| 19 | 963001 | 2 | BOLT, 1/4-20 X .625 WSH |
| 20 | 967340 | 4 | SCREW PAN HD PHL #10-24x5/8 |
| 21 | N/A | 2 | ATO/ATC BLADE TYPE 20A. FUSE |
| 22 | 181074 | 1 | SEAT SWITCH S/O |
| 23 | 181463 | 1 | FUSE HOLDER, KAWASAKI |
| 24 | 181453 | 1 | HARNESS, KAWASAKI ENGINE |
| | 191358 | 1 | HARNESS, BRIGGS ENGINE |
| 25 | 181472 | 1 | KIT, POWER POINT * |

* Optional Equipment

88 - FUEL COMPONENTS

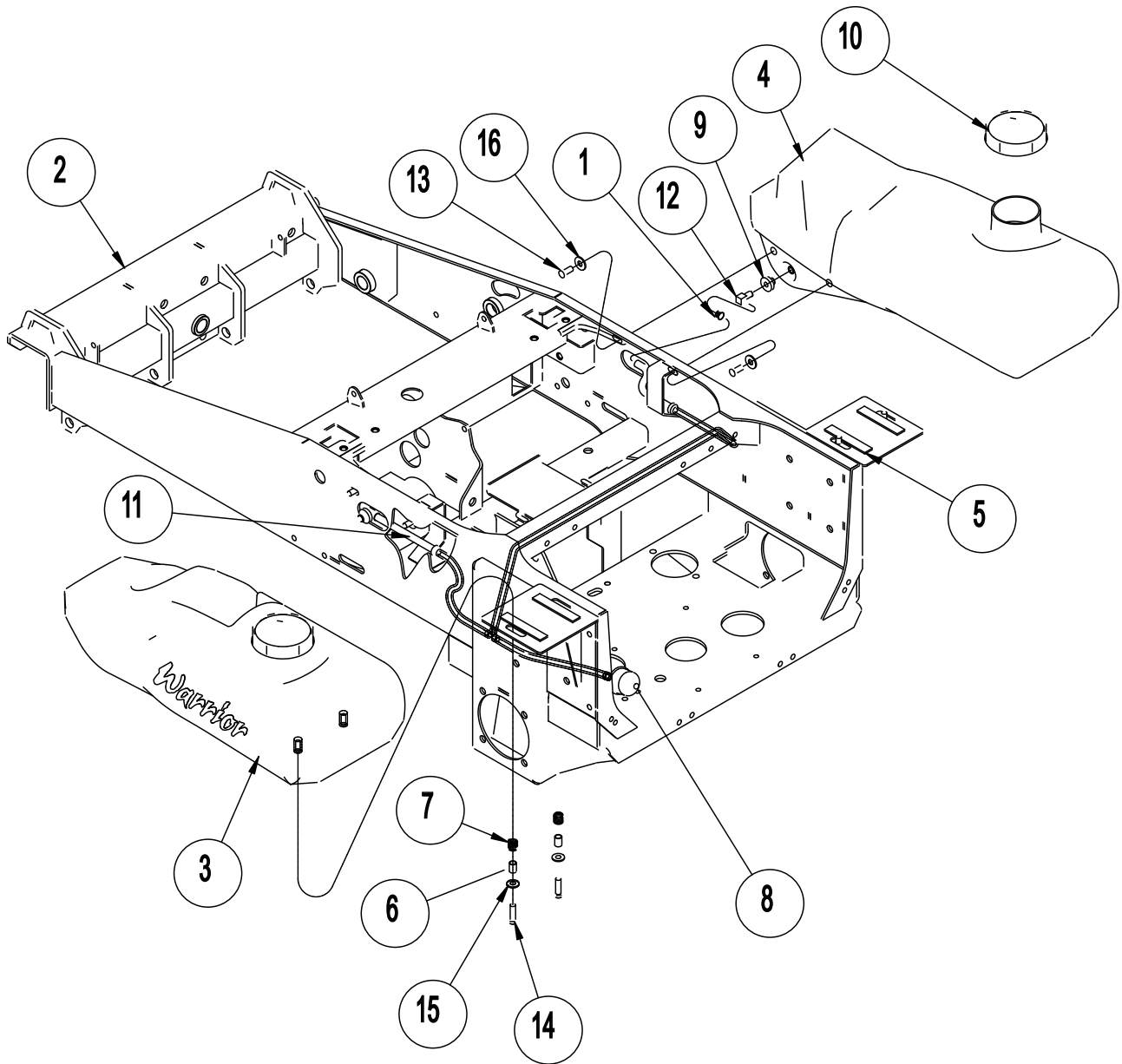

| ITEM | PART NO | QTY | DESCRIPTION |
|------|---------|-----|----------------------------------|
| 1 | 130924 | 3 | CLAMP, 1/2 SPRING HOSE |
| 2 | 181429 | 1 | WLDT, UNIBODY FRAME W/DECALS S/O |
| 3 | 181425 | 1 | TANK, LH FUEL W/GRAPHICS |
| 4 | 181424 | 1 | TANK, RH FUEL W/GRAPHICS |
| 5 | 180897 | 4 | FOAM, .125 X .750 X 4.00 |
| 6 | 181023 | 4 | SPACER, GAS TANK ATTACHMENT |
| 7 | 181027 | 4 | SPRING, COM .660 X .067 X .625 |
| 8 | 181060 | 1 | FUEL FILTER - S/O |
| 9 | 181208 | 2 | TANK FITTING, RUBBER S/O |
| 10 | 181251 | 2 | CAP, FUEL |
| 11 | 191282 | 1 | ASSY, FUEL LINE W/ CHECKVALVES |
| 12 | 191605 | 2 | FTG, 90 1/4HOSE X 1/2HOSE S/O |
| 13 | 960045 | 4 | BOLT, 3/8-16 X .750 HEX 5 Y |
| 14 | 960047 | 4 | BOLT, 3/8-16 X 1.25 HEX 5 Y |
| 15 | 960701 | 4 | WASHER, .313 REG FLAT Y |
| 16 | 960702 | 4 | WASHER, .375 REG FLAT Y |

90 - HYDRAULIC COMPONENTS

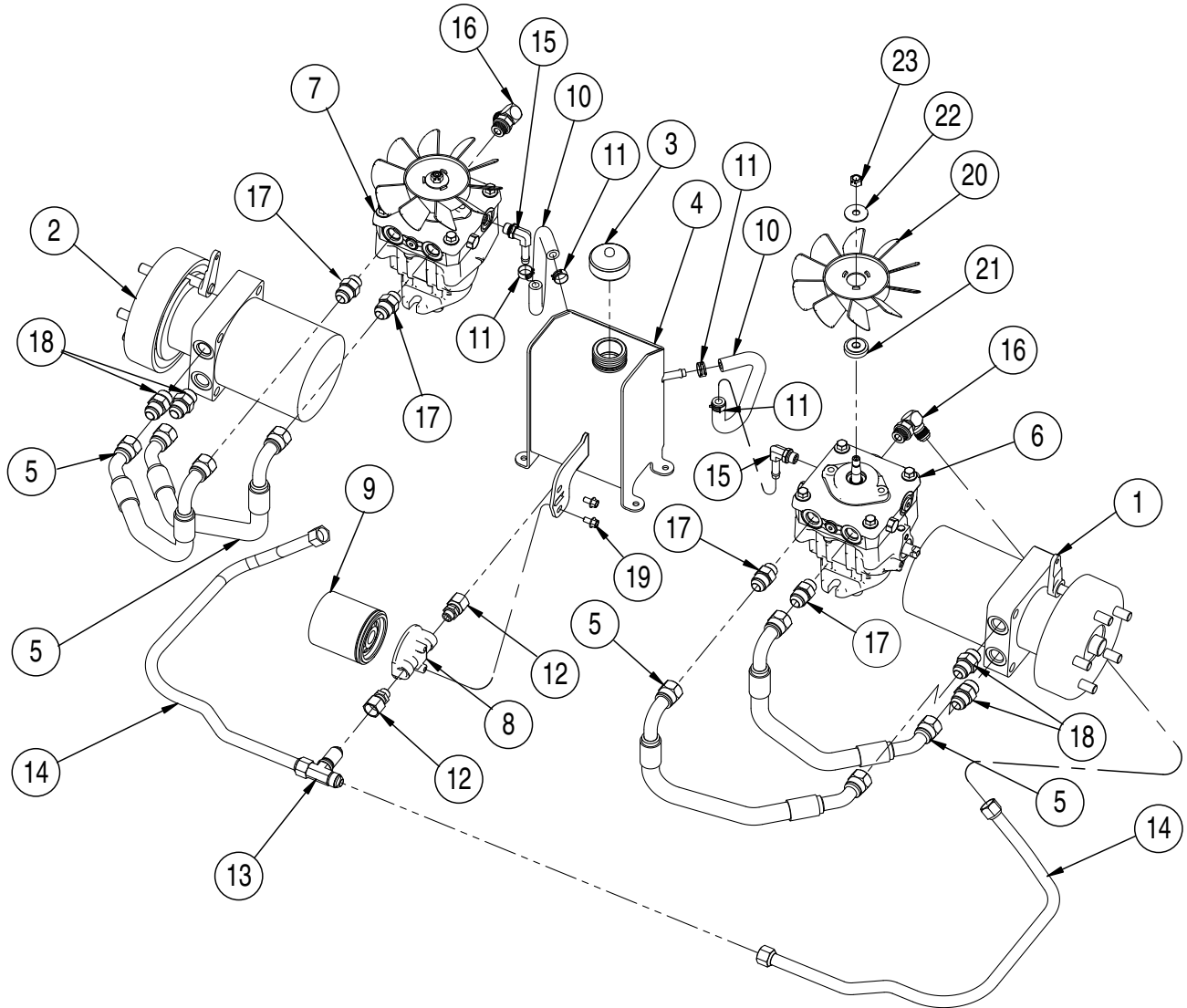

| ITEM | PART NO | QTY | DESCRIPTION |
|------|---------|--------|--|
| 1 | 180236 | 1 | MOTOR ASSY, LH WHEEL PARKER ** |
| | 181513 | 1 | MOTOR ASSY, LH WHEEL HYDRO-GEAR *** |
| 2 | 180237 | 1 | MOTOR ASSY, RH WHEEL PARKER** |
| | 181512 | 1 | MOTOR ASSY, RH WHEEL HYDRO-GEAR*** |
| 3 | 181210 | 1 | CAP, OIL RESERVOIR BREATHER |
| 4 | 181267 | 1 | TANK WLDT, OIL W/DECALS S/O |
| 5 | 180652 | 4 | HOSE - HYD 5/8 X 18.75 |
| 6 | 180831 | 1 | PUMP, LH BDP16A * |
| 7 | 180832 | 1 | PUMP, RH BDP16A * |
| 8 | 180908 | 1 | HEAD, FILTER |
| 9 | 180909 | 1 | FILTER, 25 MICRON |
| 10 | 180935 | 2 | HOSE, 3/8 X 12.5 LONG |
| 11 | 180947 | 4 | CLAMP, .690 OD HOSE PINCH |
| 12 | 181031 | 2 | FTG, #6 MALE OR x #8 FEMALE 37° JIC |
| 13 | 181032 | 1 | FTG, BULK HEAD #8 JIC TEE |
| 14 | 181035 | 2 | HOSE, #8 TOC W/ # 8 SWL 37° JIC |
| 15 | 222151 | 2 | FTG, 9/16 MOR X 3/8 HOSE 90° |
| 16 | 230668 | 2 | FTG - HYD ELBOW 3/4 O-RING, 3/4JIC |
| 17 | 313290 | 4 | ADAPTER, 3/4-16MORX7/8-14 JIC |
| 18 | 313392 | 4 | ADAPTER, 7/8-14MORX 7/8-14JIC |
| 19 | 963000 | 2 | BOLT, 1/4-20 X .500 WSH 5 |
| 20 | 180993 | 2 | FAN, BDP16 PLASTIC COOLER |
| 21 | 180994 | 2 | HUB, BDP16 FAN |
| 22 | 180995 | 2 | WASHER, .375 X 1.24 X .072 BLVL |
| 23 | 964066 | 2 | LOCKNUT, 3/8-24 CROWN |
| * | N/I | 181065 | 2 SEAL KIT, BDP16A PUMP S/O |
| ** | N/I | 181066 | 2 SEAL KIT, PARKER DF280 WHEEL MOTOR S/O |
| ** | N/I | 181370 | 4 SPRING, BRAKE RETURN |
| ** | N/I | 181371 | 2 LEVER, BRAKE (PARKER MOTOR) |
| *** | N/I | 181903 | 2 LEVER, BRAKE (HYDRO-GEAR) |
| ** | N/I | 181372 | 2 CLIP, BRAKE SHAFT |
| *** | N/I | 181565 | 2 SEAL KIT, HYDRO-GEAR WHEEL MOTOR S/O |

92 - SEAT & FOOT PLATE ASSEMBLY

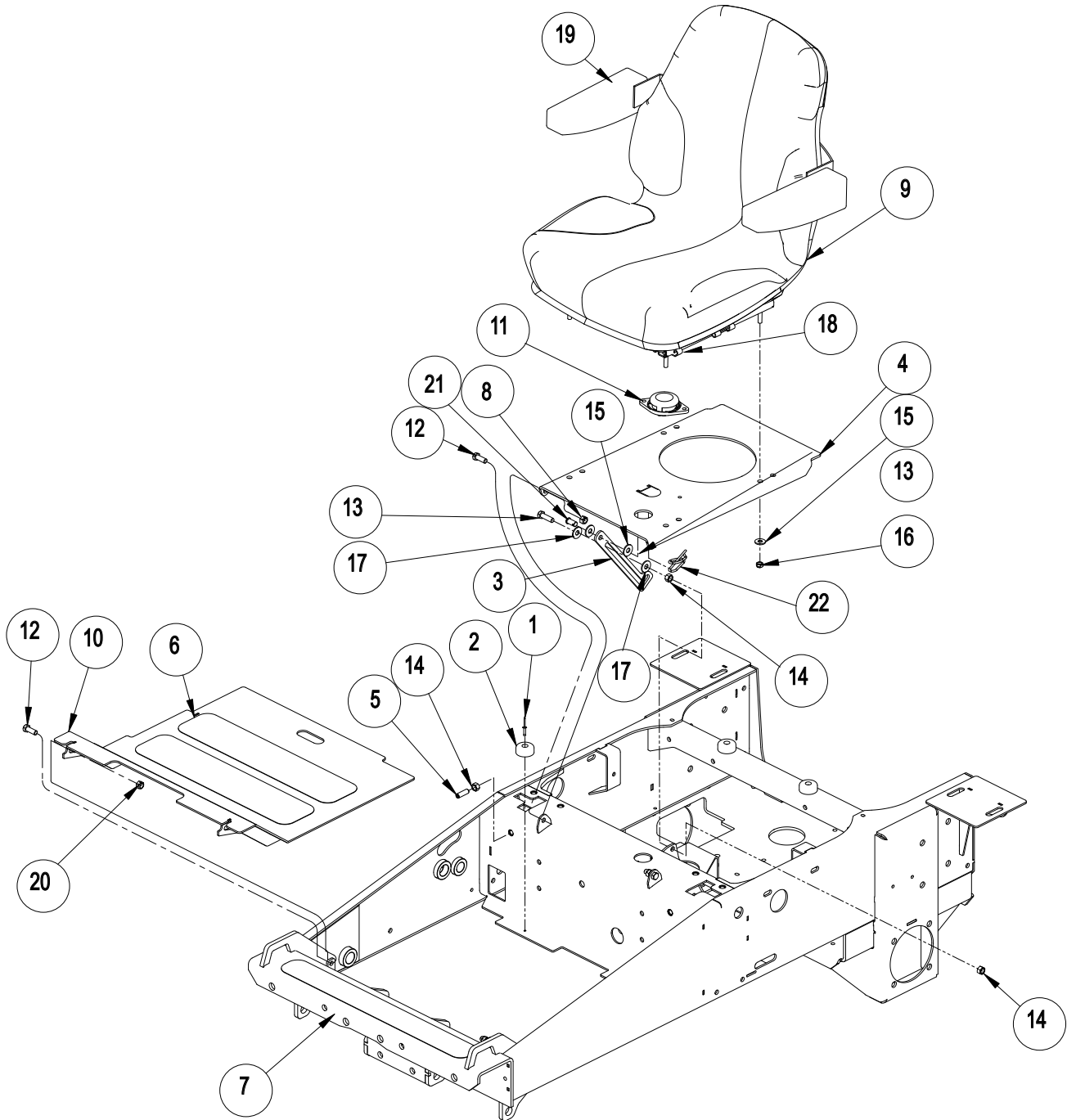

SEAT & FOOT PLATE ASSEMBLY - 93

| ITEM | PART NO | QTY | DESCRIPTION |
|------|---------|-----|--|
| 1 | 968100 | 4 | RIVET, 3/16 X .500 POP |
| 2 | 180390 | 4 | BUMPER, RUBBER .625 X 1.50 DIA |
| 3 | 180391 | 1 | BAR - SEAT LOCK |
| 4 | 181475 | 1 | PLATE, SEAT |
| 5 | 962903 | 2 | SET SCREW, 3/8-16 X 3/4 ALHD CUP |
| 6 | 180658 | 3 | TRACTION TAPE, 4 X 18 |
| 7 | 180659 | 1 | TRACTION TAPE, 2.5 X 21.5 |
| 8 | 964022 | 4 | LOCKNUT, 3/8-16 CROWN |
| 9 | 180916 | 1 | SEAT - FULL SUSPENSION |
| 10 | 181050 | 1 | FOOT PLATE S/O |
| 11 | 181074 | 1 | SEAT SWITCH S/O |
| 12 | 960046 | 4 | BOLT, 3/8-16 X 1.00 HEX 5 |
| 13 | 960047 | 1 | BOLT, 3/8-16 X 1.25 HEX 5 |
| 14 | 960502 | 5 | NUT, 3/8-16 STD HEX GR5 |
| 15 | 960701 | 6 | WASHER, .313 REG FLAT |
| 16 | 964021 | 4 | LOCKNUT, 5/16-18 CROWN |
| 17 | 960702 | 2 | WASHER, .375 REG FLAT |
| 18 | 181749 | 1 | KIT, SEAT ADJUSTER |
| 19 | 181461 | 2 | ARM REST, SINGLE SUSPENSION S/O W/HDWR |
| 20 | 964022 | 2 | LOCKNUT, 3/8-16 CROWN |
| 21 | 967176 | 1 | PIN, CLEVIS .375 x .750 x .516 |
| 22 | 967353 | 1 | RING, RUE .375 X .054 X 1.254 |
| N/I | 181811 | 1 | KIT, MILSCO ROLLER/BUMPER |
| N/I | 181812 | 1 | KIT, MILSCO DAMPENER |
| N/I | 181813 | 1 | KIT, MILSCO SPRING/CABLE |
| N/I | 181814 | 1 | KIT, MILSCO EVERRIDE CUSHION |
| N/I | 181749 | 1 | KIT, MILSCO SEAT ADJUSTER |

94 - DECK ATTACHMENT COMPONENTS

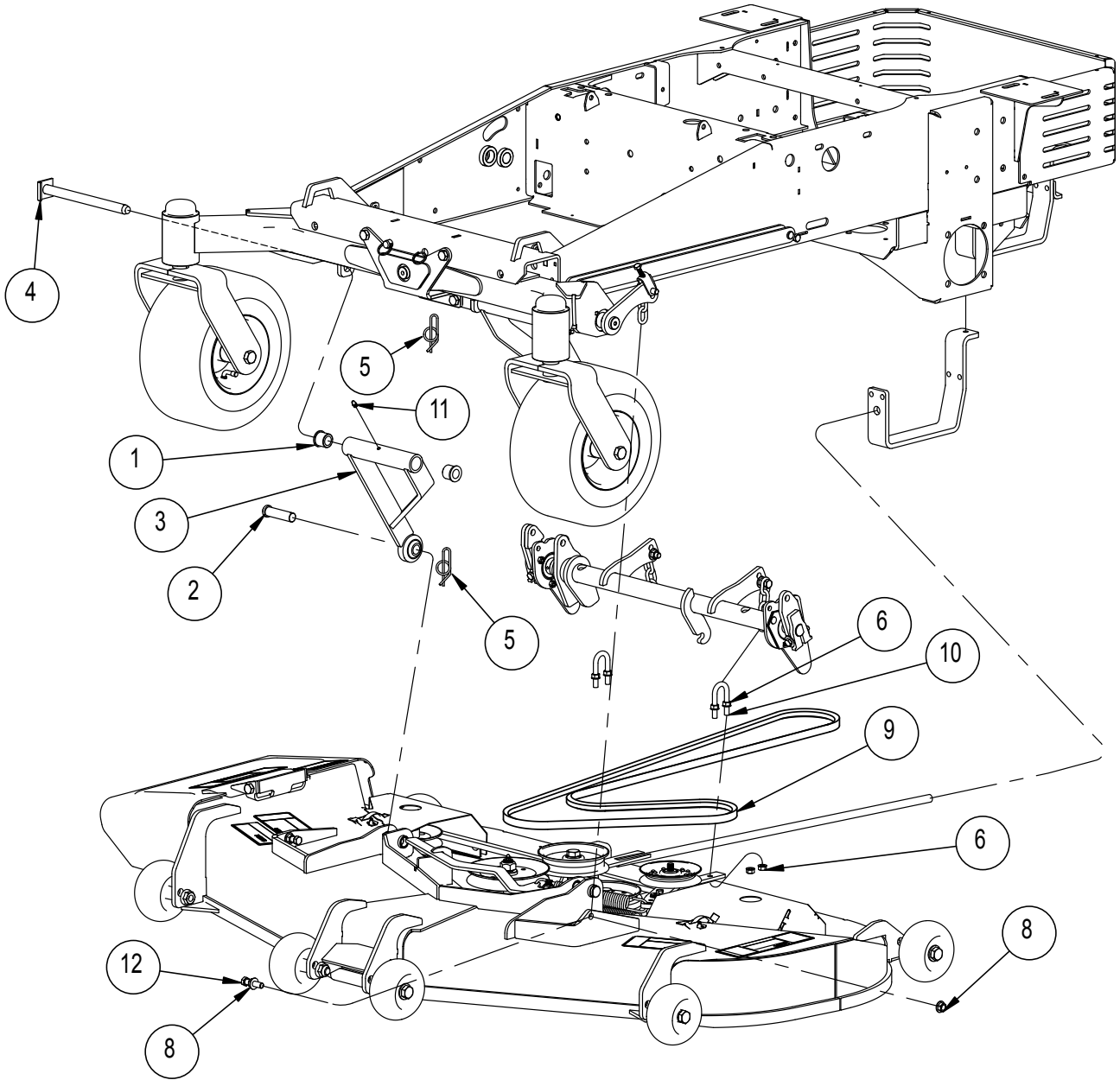

DECK ATTACHMENT COMPONENTS - 95

| ITEM | PART NO | QTY | DESCRIPTION |
|------|---------|-----|------------------------------------|
| 1 | 150079 | 4 | BUSHING, 3/4 I.D. |
| 2 | 161367 | 2 | PIN, CVS .750 X 2.75 X 2.52 |
| 3 | 181717 | 2 | PULL BAR - DECK WLDT |
| 4 | 180223 | 2 | WLDT, DRAG LINK PIN |
| 5 | 967357 | 4 | RING, RUE .750 X .080 X 2.081 |
| 6 | 964016 | 8 | LOCKNUT, 3/8-16 WHIZ |
| 7 | N/A | 1 | DECK ASSY, 60" WARRIOR |
| 8 | 967342 | 4 | LOCKNUT, 7/16-14 WHIZ |
| 9 | 181715 | 1 | BELT, B112 Kevlar (Clutch to Deck) |
| 10 | 181485 | 2 | U-BOLT SPECIAL |
| 11 | 959995 | 2 | FTG, 1/4-28 STRGT GREASE ZERK |
| 12 | 960082 | 2 | BOLT 7/16-14 X 1 3/4 GR5 |

96 - DECK LIFT/HOC COMPONENTS

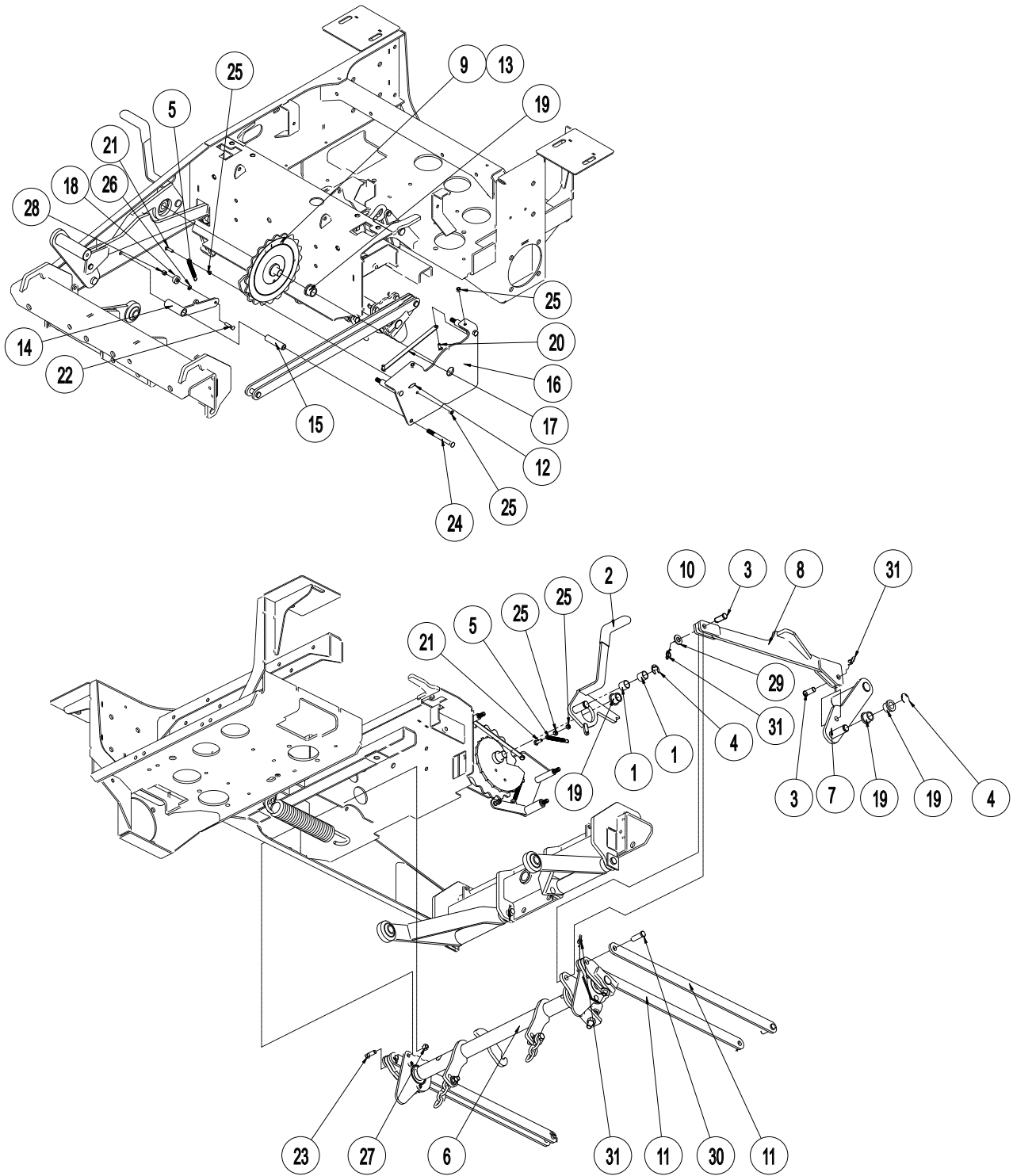

DECK LIFT/HOC COMPONENTS - 97

| ITEM | PART NO | QTY | DESCRIPTION |
|------|---------|-----|------------------------------------|
| 1 | 105546 | 2 | BRG, SLV .753 X .878 X .750 |
| 2 | 105593 | 1 | GRIP, RUBBER LEVER |
| 3 | 110330 | 2 | PIN, CVS .500 X 1.25 X 1.02 Y |
| 4 | 130886 | 2 | E-RING, .750 X .050 Y |
| 5 | 135292 | 2 | SPRING, EXT .375 X .055 X 2.25 Y |
| 6 | 180085 | 1 | ASSY, REAR LIFT ROD |
| 7 | 180685 | 1 | WLDT, FOOT ARM |
| 8 | 180687 | 1 | WLDT, FOOT CONNECTOR |
| 9 | 180693 | 1 | DECAL, HOC INCREMENT |
| 10 | 180741 | 1 | WLDT, TRANSPORTATION LOCK |
| 11 | 180898 | 4 | PLATE, CONNECTOR LINK |
| 12 | 181252 | 1 | DECAL, PATENT PENDING |
| 13 | 181335 | 1 | WLDT, CAM CONTROL W/DECALS S/O |
| 14 | 181338 | 1 | WLDT, ARM |
| 15 | 181389 | 3 | SPACER, Ø.625 X Ø.385 X 2.53 HOC Y |
| 16 | 181451 | 1 | PLATE, HOC INDICATOR |
| 17 | 181452 | 1 | PLATE, FINGER GUARD |
| 18 | 191185 | 1 | BRG, BAL .250 X .688 X 313 |
| 19 | 252126 | 4 | BUSHING, .750 X 1.00 X .750 |
| 20 | 960000 | 2 | BOLT, 1/4-20 X .500 HEX 5 Y |
| 21 | 960001 | 2 | BOLT, 1/4-20 X .750 HEX 5 Y |
| 22 | 960002 | 1 | BOLT, 1/4-20 X 1.00 HEX 5 Y |
| 23 | 960046 | 4 | BOLT, 3/8-16 X 1.00 HEX 5 Y |
| 24 | 960056 | 3 | BOLT, 3/8-16 X 3.50 HEX 5 Y |
| 25 | 960500 | 6 | NUT, 1/4-20 STD HEX GR5 Y |
| 26 | 961701 | 1 | WASHER, M6 REG FLAT Y |
| 27 | 964022 | 4 | LOCKNUT, 3/8-16 CROWN Y |
| 28 | 964048 | 1 | LOCKNUT, 1/4-20 NYLOC Y |
| 29 | 964505 | 1 | WASHER, .500 X 1.00 X .105 FLAT Y |
| 30 | 967196 | 4 | PIN, CVS .500 X 1.50 X 1.27 Y |
| 31 | 967354 | 6 | RING, RUE .500 x .062 x 1.420 |

98 - PUMP COMPONENTS

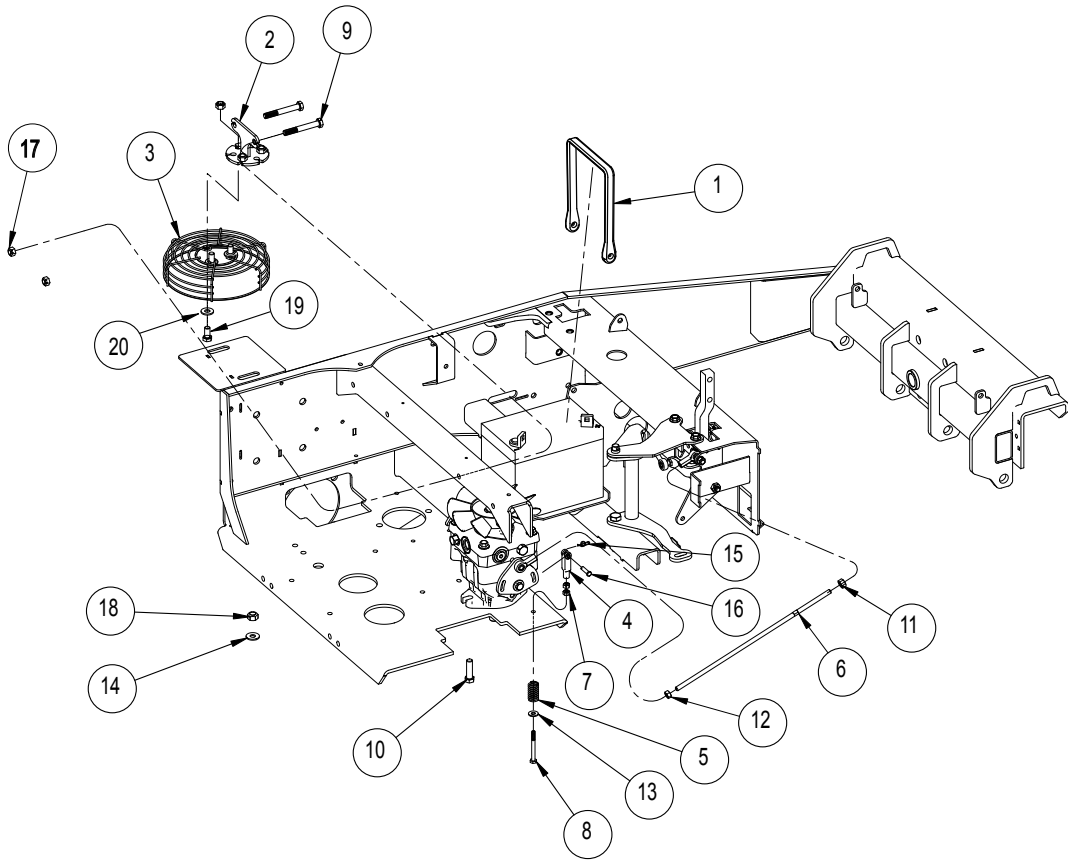

BRIGGS & STRATTON ENGINE COMPONENTS

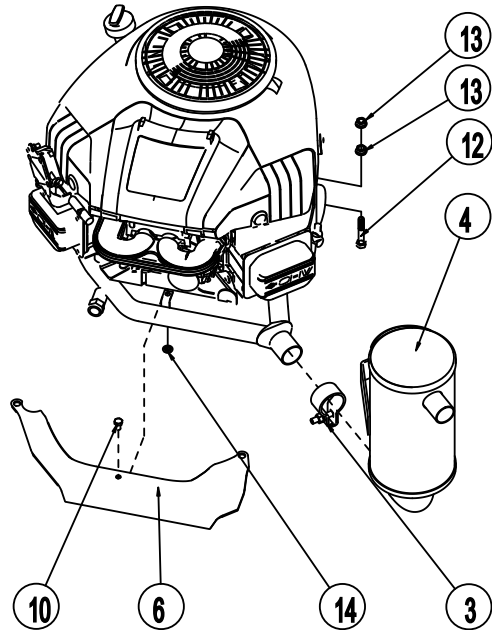
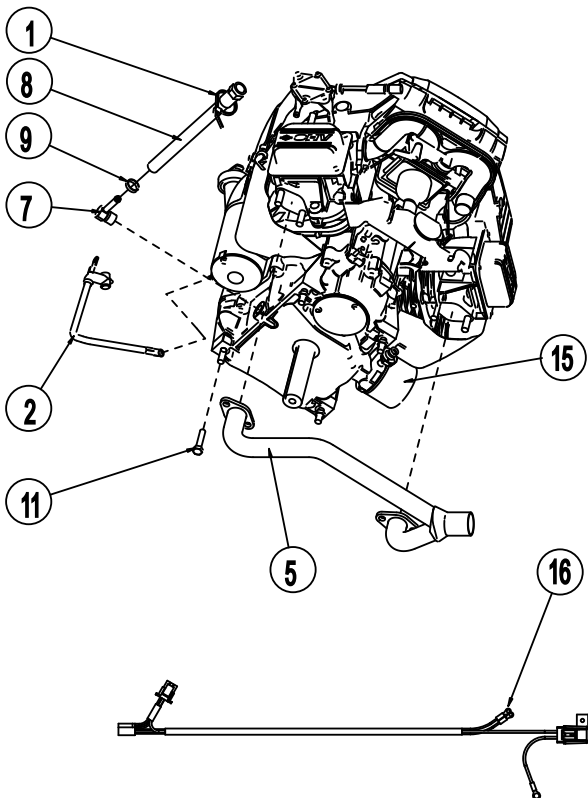

PUMP COMPONENTS - 99

| ITEM | PART NO | QTY | DESCRIPTION |
|------|---------|-----|----------------------------------|
| 1 | 181228 | 2 | BAND, 18" |
| 2 | 181360 | 2 | WLDT, FAN SHIELD MOUNTING |
| 3 | 181341 | 2 | GRILL, 7" FAN |
| 4 | 180956 | 1 | YOKE, 1/4-20 RH ADJUSTABLE |
| 5 | 180957 | 1 | SPRING, .600 x 1.5 x .092 COMP |
| 6 | 180967 | 1 | PUMP CONTROL ROD |
| 7 | 964048 | 2 | LOCKNUT, 1/4-20 NYLOC |
| 8 | 967393 | 2 | BOLT - 1/4-20 X 2.75 SOCKET HEAD |
| 9 | 960053 | 2 | BOLT, 3/8-16 X 2.75 HEX 5 |
| 10 | 960081 | 2 | BOLT, 7/16-14 X 1 1/2 GR5 |
| 11 | 967054 | 1 | NUT, 3/8-16 STD HEX GR5 |
| 12 | 967338 | 1 | NUT, 5/16-24 HEX GR5 LH |
| 13 | 960700 | 3 | WASHER, .250 REG FLAT |
| 14 | 960702 | 2 | WASHER, .375 REG FLAT |
| 15 | 967350 | 1 | RING, RUE .250 X .041 X .844 |
| 16 | 962200 | 1 | PIN, CVS .250 X 1.00 X .859 |
| 17 | 964022 | 4 | LOCKNUT, 3/8-16 CROWN |
| 18 | 964025 | 2 | LOCKNUT, 7/16-14 CROWN |
| 19 | 960045 | 6 | BOLT, 3/8-16 X .750 HEX |
| 20 | 960701 | 6 | WASHER, .313 REG FLAT |

BRIGGS & STRATTON ENGINE COMPONENTS

| ITEM | PART NO | QTY | DESCRIPTION |
|------|---------|-----|------------------------------|
| 1 | 111910 | 1 | CABLE TIE, .15 X 8.50 |
| 2 | 180842 | 1 | CABLE, 12" STARTER |
| 3 | 181158 | 1 | CLAMP, MUFFLER 27HP |
| 4 | 181506 | 1 | MUFFLER, B & S ELS ACS |
| 5 | 181527 | 1 | MANIFOLD, B & S ACS |
| 6 | 181553 | 1 | SHIELD, ACS BRIGGS MANIFOLD |
| 7 | 191398 | 1 | FTG, 90 3/8MNPT X 3/8 BARB |
| 8 | 191399 | 1 | HOSE, HYD 3/8-18 FNPT X 9.3 |
| 9 | 191800 | 1 | CLAMP, 17.5MM PINCH |
| 10 | 960000 | 1 | BOLT, 1/4-20 X .500 HEX 5 Y |
| 11 | 960025 | 3 | BOLT, 5/16-18 X 1.50 HEX 5 Y |
| 12 | 960027 | 1 | BOLT, 5/16-18 X 2.00 HEX 5 Y |
| 13 | 964019 | 2 | LOCKNUT, 5/16-18 WHIZ Y |
| 14 | 964040 | 3 | LOCKNUT, 1/4-20 WHIZ Y |
| 15 | 191631 | 1 | FILTER, BRIGG'S PREMIUM |
| 16 | 191358 | 1 | PIGTAIL, BRIGG'S |

100 - ENGINE COMPONENTS

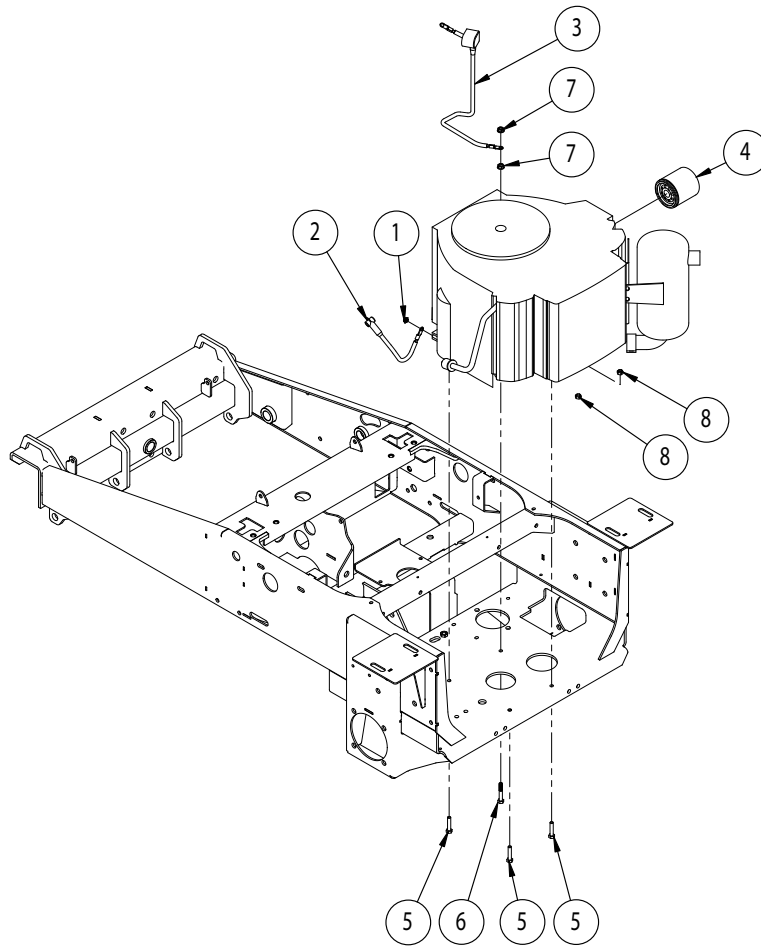

27 H.P. KOHLER ENGINE/EXHAUST COMPONENTS

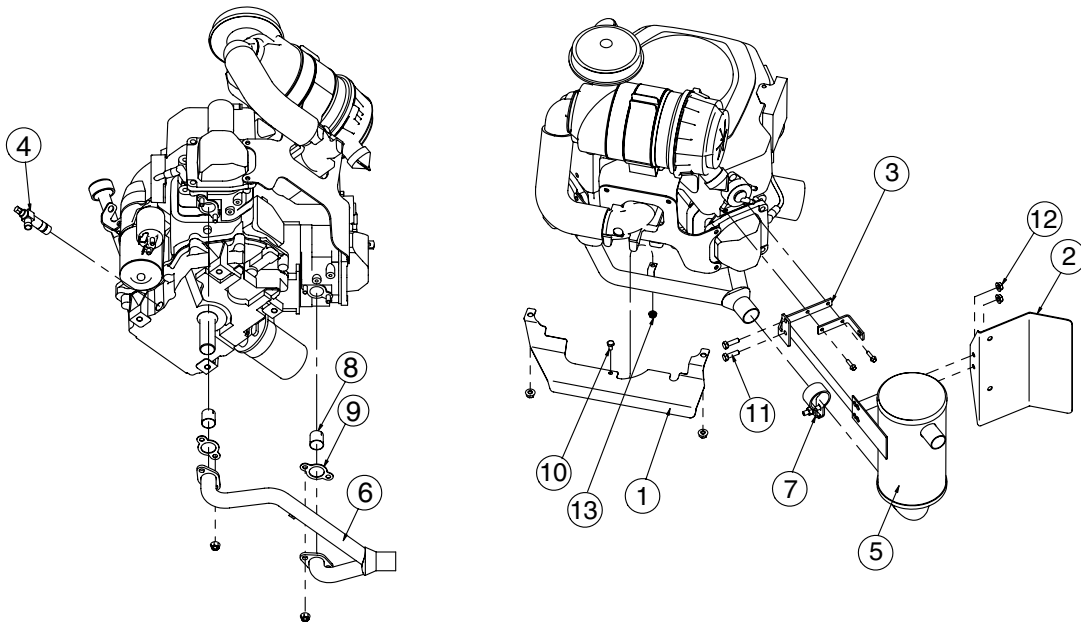

| ITEM | PART NO | QTY | DESCRIPTION |
|------|---------|-----|--|
| 1 | 964040 | 1 | LOCKNUT, 1/4-20 WHIZ |
| 2 | 180842 | 1 | STARTER CABLE - 12" |
| 3 | 180843 | 1 | BATTERY GROUND CABLE - 20" |
| 4 | 181073 | 1 | FILTER, ENGINE OIL - KAWASAKI |
| | 191190 | 1 | FILTER, ENGINE OIL - KOHLER |
| | 191631 | 1 | FILTER, ENGINE OIL - BRIGGS & STRATTON |
| 5 | 960025 | 3 | BOLT, 5/16-18 X 1.50 HEX 5 |
| 6 | 960027 | 1 | BOLT, 5/16-18 X 2.00 HEX 5 |
| 7 | 964019 | 2 | LOCKNUT, 5/16-18 WHIZ |
| 8 | 964021 | 3 | LOCKNUT, 5/16-18 CROWN |

27 H.P. KOHLER ENGINE/EXHAUST COMPONENTS

| ITEM | PART NO | QTY | DESCRIPTION |
|------|---------|-----|----------------------------|
| 1 | 181145 | 1 | SHEILD, MUFFLER-27HP HOR. |
| 2 | 181146 | 1 | SHEILD, MUFFLER-27HP VERT. |
| 3 | 181147 | 1 | BRACKET, MUFFLER 27HP |
| 4 | 181151 | 1 | VALVE, ENGINE OIL DRAIN |
| 5 | 181153 | 1 | MUFFLER, KOHLER CV-VERT |
| 6 | 181157 | 1 | MANIFOLD, KOHLER CV-ACS |
| 7 | 181158 | 1 | CLAMP, MUFFLER 27HP |
| 8 | 181163 | 2 | SLEEVE, INSULATOR |
| 9 | 181162 | 1 | KIT, GASKET W/NUTS |
| 10 | 960000 | 1 | BOLT, 1/4-20 X .500 HEX 5 |
| 11 | 960023 | 2 | BOLT, 5/16-18 X 1.00 HEX 5 |
| 12 | 964019 | 2 | LOCKNUT, 5/16-18 WHIZ |
| 13 | 964040 | 1 | LOCKNUT, 1/4-20 WHIZ |

102 - MOTION CONTROL ASSEMBLY

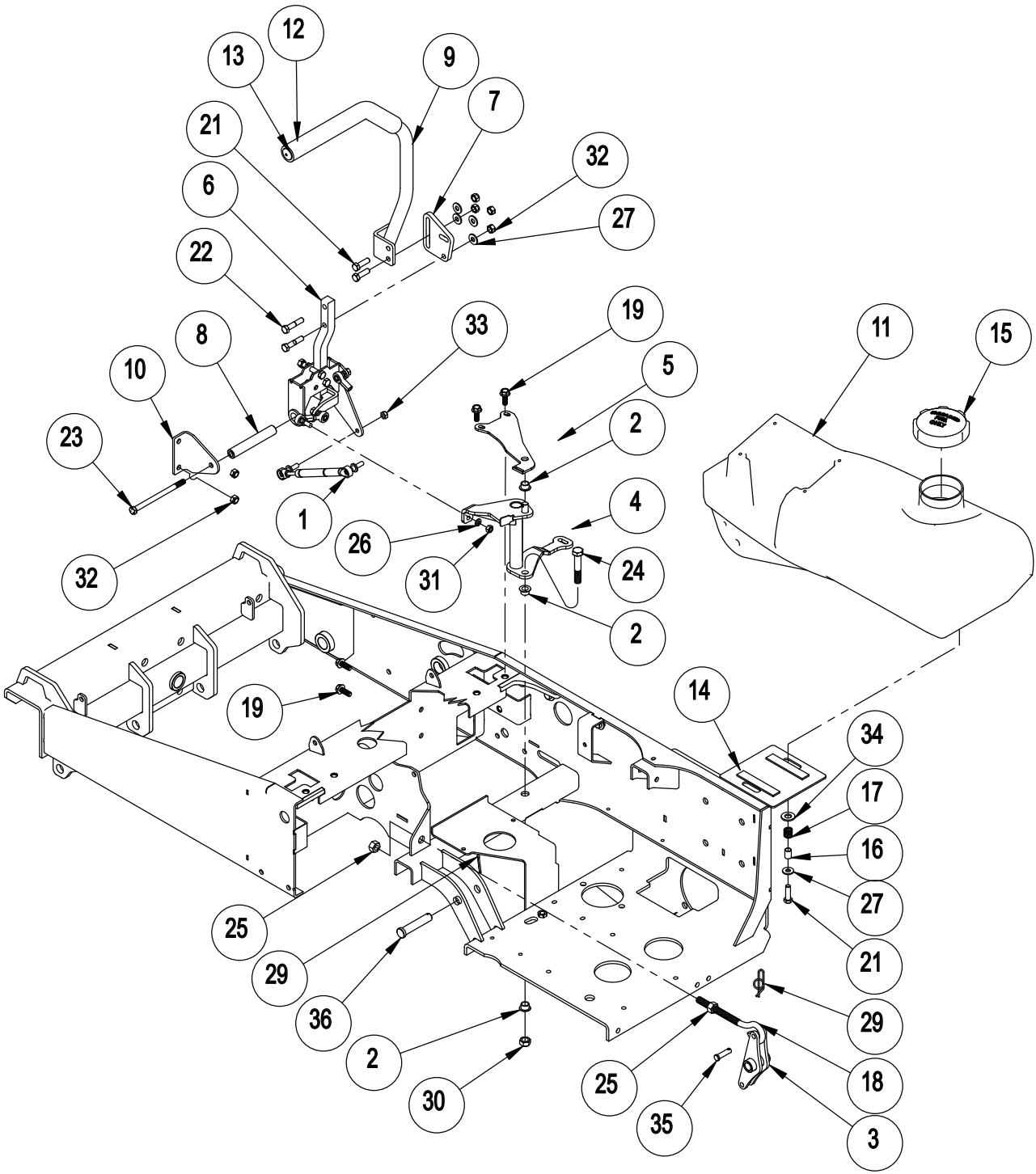

MOTION CONTROL ASSEMBLY - 103

| ITEM | PART NO | QTY | DESCRIPTION |
|------|---------|-----|---------------------------------|
| 1 | 180231 | 1 | DAMPNER, STEERING CONTROL |
| 2 | 180354 | 3 | BEARING SHLD 1/2" |
| 3 | 180436 | 1 | SPRING PIVOT WLDT |
| 4 | 181443 | 1 | PARK BRAKE CONTROL ARM RH |
| N/I | 181444 | 1 | PARK BRAKE CONTROL ARM LH |
| 5 | 181447 | 1 | EAR, RH BRAKE PIVOT |
| NI | 181448 | 1 | EAR, LH BRAKE PIVOT |
| 6 | 180530 | 1 | HANDLE ASSY RH |
| NI | 180531 | 1 | HANDLE ASSY LH |
| 7 | 180539 | 1 | HANDLE HEIGHT PLATE |
| 8 | 180543 | 1 | HANDLE SPACER, .75 X .406 |
| 9 | 181349 | 1 | WLDT, RH STEERING HANDLE W/GRIP |
| NI | 181350 | 1 | WLDT, LH STEERING HANDLE W/GRIP |
| 10 | 180590 | 1 | PLATE, BENT |
| 11 | 181184 | 1 | FUEL TANK, RH S/O W/FITTINGS |
| | 181185 | 1 | FUEL TANK, LH S/O W/FITTINGS |
| 12 | 180617 | 1 | GRIP, FOAM |
| 13 | 180639 | 1 | END PLUG |
| 14 | 180897 | 2 | FOAM, 1/8 X 3/4 X 4.0 LONG |
| 15 | 181251 | 1 | CAP, UNLEADED FUEL |
| 16 | 181023 | 4 | SPACER, GAS TANK ATTACHMENT |
| 17 | 181027 | 4 | SPRING, COM .660 X .067 X .625 |
| 18 | 250356 | 1 | EYEBOLT - .5 X 6.9 |
| 19 | 960044 | 4 | BOLT, 3/8-16 X 1.00 FGH 8 |
| 20 | 960045 | 2 | BOLT, 3/8-16 X .750 HEX 5 |
| 21 | 960047 | 6 | BOLT, 3/8-16 X 1.25 HEX 5 |
| 22 | 960049 | 2 | BOLT, 3/8-16 X 1.75 HEX 5 |
| 23 | 960063 | 1 | BOLT, 3/8-16 X 5.50 HEX 5 |
| 24 | 960119 | 1 | BOLT 1/2-13 X 2.75 G5 |
| 25 | 960504 | 2 | NUT, 1/2-13 STD HEX GR5 |
| 26 | 960601 | 1 | WASHER, .313 MED SPRG LOCK |
| 27 | 960701 | 8 | WASHER, .313 REG FLAT |
| 28 | 960702 | 2 | WASHER, .375 REG FLAT |
| 29 | 967353 | 2 | RING, RUE .375 X .054 X 1.254 |
| 30 | 964000 | 1 | LOCKNUT, 1/2-13 CROWN |
| 31 | 964003 | 1 | NUT, 5/16-24 STD HEX GR5 |
| 32 | 964022 | 6 | LOCKNUT, 3/8-16 CROWN |
| 33 | 964047 | 2 | LOCKNUT, M8-1.25 CROWN |
| 34 | 964505 | 4 | WASHER, .500 X 1.00 X .105 FLAT |
| 35 | 967013 | 1 | PIN, CVS .375 X 1.38 X 1.14 |
| 36 | 967249 | 1 | PIN, CVS .625 X 3.00 X 2.77 |

104 - PARTS LIST

| PART NO. | PAGE | REF | PART NO. | PAGE | REF |
|----------|------|-----|----------|------|-----|
| 102770 | 87 | 1 | 161367 | 95 | 2 |
| 103906 | 65 | 1 | 161573 | 65 | 11 |
| 104024 | 79 | 1 | 162146 | 65 | 12 |
| 104657 | 65 | 2 | 162701 | 65 | 13 |
| 104834 | 65 | 3 | 162779 | 65 | 14 |
| 105546 | 65 | 4 | 162801 | 65 | 15 |
| 105546 | 79 | 2 | 180046 | 83 | 2 |
| 105546 | 97 | 1 | 180055 | 67 | 8 |
| 105591 | 67 | 1 | 180085 | 83 | 3 |
| 105593 | 97 | 2 | 180085 | 85 | 3 |
| 105596 | 67 | 2 | 180085 | 97 | 6 |
| 105684 | 75 | 10 | 180223 | 95 | 4 |
| 110330 | 97 | 3 | 180231 | 103 | 1 |
| 111910 | 99 | 1 | 180235 | 81 | 1 |
| 112614 | 65 | 5 | 180236 | 85 | 4 |
| 112616 | 65 | 24 | 180236 | 91 | 1 |
| 130885 | 67 | 3 | 180237 | 85 | N/I |
| 130886 | 97 | 4 | 180237 | 91 | 2 |
| 130923 | 87 | 17 | 180249 | 73 | 1 |
| 130924 | 89 | 1 | 180256 | 67 | 10 |
| 135139 | 65 | 6 | 180257 | 67 | 11 |
| 135292 | 97 | 5 | 180273 | 75 | 3 |
| 136574 | 75 | 1 | 180273 | 87 | 5 |
| 136574 | 87 | 3 | 180334 | 71 | 11 |
| 145551 | 71 | 6 | 180354 | 79 | 3 |
| 145552 | 71 | 12 | 180354 | 85 | 5 |
| 145555 | 71 | 7 | 180354 | 103 | 2 |
| 145557 | 71 | 5 | 180390 | 93 | 2 |
| 145561 | 71 | 10 | 180391 | 93 | 3 |
| 150079 | 95 | 1 | 180436 | 103 | 3 |
| 150109 | 67 | 7 | 180494 | 65 | 18 |
| 150110 | 69 | 1 | 180496 | 65 | 20 |
| 160001 | 71 | 8 | 180501 | 65 | 19 |
| 160100 | 65 | 8 | 180530 | 103 | 6 |
| 160116 | 71 | 9 | 180531 | 103 | NI |
| 160169 | 65 | 9 | 180532 | 73 | |
| 160176 | 77 | 1 | 180536 | 73 | |
| 161074 | 79 | 28 | 180539 | 103 | 7 |
| 161367 | 65 | 10 | 180543 | 103 | 8 |

| PART NO. | PAGE | REF | PART NO. | PAGE | REF |
|----------|------|-----|----------|------|-----|
| 180544 | 73 | 2 | 180844 | 87 | 11 |
| 180545 | 73 | 3 | 180857 | 71 | 11 |
| 180590 | 103 | 10 | 180860 | 69 | 3 |
| 180591 | 79 | 4 | 180868 | 69 | 4 |
| 180604 | 81 | 2 | 180880 | 85 | 7 |
| 180606 | 73 | 4 | 180897 | 89 | 5 |
| 180617 | 103 | 12 | 180897 | 103 | 14 |
| 180620 | 75 | 5 | 180898 | 83 | 6 |
| 180620 | 87 | 6 | 180898 | 97 | 11 |
| 180629 | 81 | 3 | 180908 | 91 | 8 |
| 180639 | 103 | 13 | 180909 | 91 | 9 |
| 180640 | 87 | 7 | 180916 | 93 | 9 |
| 180641 | 79 | | 180923 | 79 | 9 |
| 180652 | 77 | 1 | 180923 | 87 | 13 |
| 180652 | 91 | 5 | 180924 | 81 | 11 |
| 180658 | 93 | 6 | 180925 | 67 | 5 |
| 180659 | 93 | 7 | 180925 | 71 | * |
| 180670 | 79 | 6 | 180927 | 79 | 10 |
| 180685 | 97 | 7 | 180928 | 79 | 11 |
| 180687 | 97 | 8 | 180935 | 77 | 3 |
| 180693 | 97 | 9 | 180935 | 91 | 10 |
| 180721 | 81 | 4 | 180947 | 77 | 4 |
| 180724 | 65 | 16 | 180947 | 91 | 11 |
| 180741 | 97 | 10 | 180955 | 77 | 5 |
| 180778 | 65 | 20 | 180956 | 99 | 4 |
| 180799 | 75 | 6 | 180957 | 99 | 5 |
| 180799 | 87 | 8 | 180961 | 73 | 5 |
| 180830 | 83 | 5 | 180962 | 79 | 14 |
| 180831 | 77 | 2 | 180967 | 99 | 6 |
| 180831 | 91 | 6 | 180968 | 85 | 8 |
| 180832 | 77 | 2 | 180977 | 67 | 12 |
| 180832 | 91 | 7 | 180981 | 85 | 9 |
| 180836 | 79 | 8 | 180982 | 77 | 11 |
| 180841 | 69 | 2 | 180983 | 67 | 13 |
| 180842 | 87 | 9 | 180983 | 69 | 5 |
| 180842 | 99 | 2 | 180991 | 85 | 10 |
| 180842 | 101 | 2 | 180992 | 67 | 15 |
| 180843 | 87 | 10 | 180993 | 77 | 15 |
| 180843 | 101 | 3 | 180993 | 91 | 20 |

106 - PARTS LIST

| PART NO. | PAGE | REF | PART NO. | PAGE | REF |
|----------|------|-----|----------|------|-----|
| 180994 | 91 | 21 | 181145 | 101 | 1 |
| 180995 | 91 | 22 | 181146 | 101 | 2 |
| 180999 | 79 | 15 | 181147 | 101 | 3 |
| 181010 | 65 | 22 | 181148 | 87 | 11 |
| 181023 | 89 | 6 | 181151 | 101 | 4 |
| 181023 | 103 | 16 | 181153 | 101 | 5 |
| 181026 | 65 | 25 | 181157 | 101 | 6 |
| 181027 | 89 | 7 | 181158 | 99 | 3 |
| 181027 | 103 | 17 | 181158 | 101 | 7 |
| 181031 | 91 | 12 | 181162 | 101 | 9 |
| 181032 | 91 | 13 | 181163 | 101 | 8 |
| 181035 | 91 | 14 | 181173 | 65 | 29 |
| 181036 | 65 | 24 | 181174 | 67 | 16 |
| 181042 | 65 | 25 | 181174 | 67 | 28 |
| 181043 | 65 | 26 | 181184 | 103 | 11 |
| 181050 | 93 | 10 | 181185 | 103 | 11 |
| 181051 | 81 | 5 | 181188 | 65 | 26 |
| 181060 | 89 | 8 | 181194 | 65 | 31 |
| 181062 | 65 | 27 | 181208 | 89 | 9 |
| 181065 | 77 | N/I | 181210 | 91 | 3 |
| 181065 | 91 | N/I | 181228 | 99 | 1 |
| 181066 | 91 | N/I | 181237 | 79 | 12 |
| 181071 | 73 | 1 | 181239 | 65 | 31 |
| 181072 | 73 | 2 | 181251 | 89 | 10 |
| 181073 | 101 | 4 | 181251 | 103 | 15 |
| 181074 | 87 | 22 | 181252 | 97 | 12 |
| 181074 | 93 | 11 | 181258 | 65 | 33 |
| 181090 | 75 | 7 | 181259 | 85 | 2 |
| 181092 | 75 | 4 | 181267 | 91 | 4 |
| 181105 | 79 | 13 | 181288 | 65 | 34 |
| 181106 | 79 | 5 | 181296 | 75 | 2 |
| 181115 | 65 | 71 | 181296 | 87 | 4 |
| 181118 | 75 | 11 | 181330 | 81 | 11 |
| 181119 | 75 | 3 | 181335 | 97 | 13 |
| 181120 | 65 | 69 | 181338 | 97 | 14 |
| 181129 | 65 | 70 | 181341 | 99 | 3 |
| 181139 | 65 | 28 | 181342 | 81 | 1 |
| 181143 | 75 | | 181349 | 103 | 9 |
| 181143 | 87 | 5 | 181350 | 103 | NI |

| PART NO. | PAGE | REF | PART NO. | PAGE | REF |
|----------|------|-----|----------|------|-----|
| 181360 | 99 | 2 | 181527 | 99 | 5 |
| 181364 | 83 | 4 | 181553 | 99 | 6 |
| 181367 | 65 | 35 | 181561 | 77 | 5 |
| 181368 | 65 | 35 | 181565 | 91 | N/I |
| 181370 | 91 | N/I | 181566 | 67 | 14 |
| 181371 | 91 | N/I | 181571 | 73 | 4 |
| 181372 | 91 | N/I | 181572 | 77 | 6 |
| 181389 | 97 | 15 | 181591 | 77 | 17 |
| 181408 | 65 | 30 | 181592 | 77 | 18 |
| 181424 | 89 | 4 | 181593 | 77 | 4 |
| 181425 | 89 | 3 | 181594 | 77 | 21 |
| 181429 | 83 | 1 | 181613 | 65 | 32 |
| 181429 | 89 | 2 | 181707 | 65 | 25 |
| 181432 | 67 | 9 | 181708 | 65 | 20 |
| 181441 | 75 | 7 | 181709 | 65 | 18 |
| 181442 | 87 | 12 | 181711 | 65 | 24 |
| 181443 | 85 | N/I | 181715 | 95 | 9 |
| 181443 | 103 | 4 | 181717 | 95 | 3 |
| 181444 | 85 | 6 | 181719 | 65 | 35 |
| 181444 | 103 | N/I | 181727 | 79 | |
| 181447 | 103 | 5 | 181749 | 93 | 18 |
| 181448 | 103 | NI | 181749 | 93 | N/I |
| 181451 | 97 | 16 | 181788 | 77 | 22 |
| 181452 | 97 | 17 | 181811 | 93 | N/I |
| 181453 | 87 | 24 | 181812 | 93 | N/I |
| 181460 | 65 | 37 | 181813 | 93 | N/I |
| 181461 | 93 | 19 | 181814 | 93 | N/I |
| 181463 | 87 | 23 | 181818 | 71 | 2 |
| 181470 | 75 | 4 | 181821 | 65 | 7 |
| 181472 | 87 | 25 | 181822 | 65 | 17 |
| 181475 | 93 | 4 | 181822 | 71 | 13 |
| 181485 | 95 | 10 | 181823 | 65 | 21 |
| 181506 | 99 | 4 | 181838 | 73 | 3 |
| 181512 | 91 | 2 | 181903 | 91 | N/I |
| 181513 | 85 | 1 | 181907 | 65 | 21 |
| 181513 | 85 | 4 | 181908 | 65 | 39 |
| 181513 | 91 | 1 | 181909 | 65 | 36 |
| 181514 | 77 | 3 | 181910 | 71 | * |
| 181517 | 85 | 10 | 181911 | 65 | 21 |

108 - PARTS LIST

| PART NO. | PAGE | REF | PART NO. | PAGE | REF |
|----------|------|-----|----------|------|-----|
| 181912 | 65 | 36 | 959995 | 67 | 17 |
| 181917 | 71 | * | 959995 | 71 | 1 |
| 181926 | 65 | 72 | 959995 | 79 | 27 |
| 181929 | 65 | 36 | 959995 | 83 | 7 |
| 182189 | 67 | 6 | 959995 | 95 | 11 |
| 191185 | 97 | 18 | 960000 | 97 | 20 |
| 191190 | 101 | 4 | 960000 | 99 | 10 |
| 191203 | 79 | 7 | 960000 | 101 | 10 |
| 191256 | 87 | 2 | 960001 | 97 | 21 |
| 191282 | 89 | 11 | 960002 | 85 | 12 |
| 191347 | 65 | 38 | 960002 | 97 | 22 |
| 191358 | 87 | 24 | 960004 | 87 | 14 |
| 191358 | 99 | 16 | 960023 | 101 | 11 |
| 191398 | 99 | 7 | 960024 | 65 | 42 |
| 191399 | 99 | 8 | 960025 | 99 | 11 |
| 191509 | 85 | | 960025 | 101 | 5 |
| 191605 | 89 | 12 | 960027 | 87 | 15 |
| 191625 | 85 | 1 | 960027 | 99 | 12 |
| 191631 | 99 | 15 | 960027 | 101 | 6 |
| 191631 | 101 | 4 | 960044 | 103 | 19 |
| 191632 | 73 | 5 | 960045 | 89 | 13 |
| 191800 | 99 | 9 | 960045 | 99 | 19 |
| 222151 | 77 | 6 | 960045 | 103 | 20 |
| 222151 | 91 | 15 | 960046 | 65 | 43 |
| 230668 | 77 | 7 | 960046 | 75 | 1 |
| 230668 | 91 | 16 | 960046 | 79 | 17 |
| 250083 | 79 | 16 | 960046 | 81 | 6 |
| 250356 | 103 | 18 | 960046 | 85 | 13 |
| 251060 | 69 | 6 | 960046 | 93 | 12 |
| 251061 | 69 | 7 | 960046 | 97 | 23 |
| 251907 | 85 | 11 | 960047 | 77 | 7 |
| 252126 | 73 | 6 | 960047 | 89 | 14 |
| 252126 | 97 | 19 | 960047 | 93 | 13 |
| 313290 | 77 | 8 | 960047 | 103 | 21 |
| 313290 | 91 | 17 | 960049 | 73 | 7 |
| 313392 | 91 | 18 | 960049 | 103 | 22 |
| 959994 | 65 | 40 | 960051 | 67 | 18 |
| 959995 | 65 | 41 | 960051 | 69 | 8 |

| PART NO. | PAGE | REF | PART NO. | PAGE | REF |
|----------|------|-----|----------|------|-----|
| 960051 | 73 | 8 | 960528 | 75 | 18 |
| 960052 | 65 | 44 | 960529 | 75 | 17 |
| 960053 | 99 | 9 | 960601 | 73 | 9 |
| 960056 | 97 | 24 | 960601 | 77 | 12 |
| 960059 | 65 | 45 | 960601 | 103 | 26 |
| 960063 | 79 | 18 | 960602 | 75 | 5 |
| 960063 | 103 | 23 | 960602 | 79 | 19 |
| 960079 | 77 | 8 | 960604 | 75 | 13 |
| 960081 | 99 | 10 | 960604 | 77 | 14 |
| 960082 | 65 | 46 | 960700 | 99 | 13 |
| 960082 | 67 | 19 | 960701 | 77 | 9 |
| 960082 | 69 | 9 | 960701 | 89 | 15 |
| 960082 | 95 | 12 | 960701 | 93 | 15 |
| 960113 | 83 | 8 | 960701 | 99 | 20 |
| 960114 | 75 | 15 | 960701 | 103 | 27 |
| 960114 | 77 | 9 | 960702 | 65 | 53 |
| 960115 | 65 | 47 | 960702 | 67 | 21 |
| 960118 | 75 | 14 | 960702 | 69 | 11 |
| 960118 | 77 | 10 | 960702 | 75 | 2 |
| 960119 | 85 | 14 | 960702 | 89 | 16 |
| 960119 | 103 | 24 | 960702 | 93 | 17 |
| 960121 | 77 | 19 | 960702 | 99 | 14 |
| 960122 | 75 | 8 | 960702 | 103 | 28 |
| 960122 | 77 | 11 | 960703 | 75 | 16 |
| 960128 | 65 | 48 | 960703 | 77 | 15 |
| 960155 | 65 | 50 | 960703 | 79 | 20 |
| 960167 | 65 | 51 | 960704 | 65 | 54 |
| 960176 | 67 | 20 | 960704 | 75 | 6 |
| 960500 | 97 | 25 | 960711 | 71 | 3 |
| 960502 | 65 | 52 | 961284 | 77 | 10 |
| 960502 | 77 | 12 | 961701 | 97 | 26 |
| 960502 | 93 | 14 | 962018 | 65 | 55 |
| 960504 | 69 | 10 | 962200 | 99 | 16 |
| 960504 | 75 | 12 | 962903 | 93 | 5 |
| 960504 | 77 | 13 | 963000 | 81 | 8 |
| 960504 | 85 | 16 | 963000 | 91 | 19 |
| 960504 | 103 | 25 | 963001 | 87 | 19 |
| 960526 | 81 | 7 | 963020 | 65 | 68 |

110 - PARTS LIST

| PART NO. | PAGE | REF | PART NO. | PAGE | REF |
|----------|------|-----|----------|------|-----|
| 964000 | 65 | 56 | 964040 | 101 | 13 |
| 964000 | 83 | 10 | 964047 | 103 | 33 |
| 964000 | 103 | 30 | 964048 | 85 | 17 |
| 964003 | 73 | 10 | 964048 | 97 | 28 |
| 964003 | 77 | 13 | 964048 | 99 | 7 |
| 964003 | 103 | 31 | 964066 | 77 | 14 |
| 964005 | 65 | 57 | 964066 | 91 | 23 |
| 964016 | 65 | 58 | 964500 | 65 | 49 |
| 964016 | 67 | 22 | 964502 | 65 | 61 |
| 964016 | 95 | 6 | 964505 | 97 | 29 |
| 964019 | 65 | 59 | 964505 | 103 | 34 |
| 964019 | 87 | 16 | 966045 | 65 | 62 |
| 964019 | 99 | 13 | 966045 | 71 | 4 |
| 964019 | 101 | 7 | 966053 | 79 | 22 |
| 964019 | 101 | 12 | 967013 | 79 | 23 |
| 964021 | 69 | 12 | 967013 | 85 | 18 |
| 964021 | 93 | 16 | 967013 | 103 | 35 |
| 964021 | 101 | 8 | 967018 | 79 | 24 |
| 964022 | 65 | 60 | 967054 | 85 | 19 |
| 964022 | 67 | 23 | 967054 | 99 | 11 |
| 964022 | 69 | 13 | 967057 | 83 | 11 |
| 964022 | 73 | 11 | 967087 | 65 | 63 |
| 964022 | 77 | 16 | 967106 | 75 | 10 |
| 964022 | 81 | 9 | 967106 | 77 | 20 |
| 964022 | 93 | 8 | 967152 | 69 | 14 |
| 964022 | 93 | 20 | 967176 | 93 | 21 |
| 964022 | 97 | 27 | 967187 | 65 | 64 |
| 964022 | 99 | 17 | 967196 | 83 | 12 |
| 964022 | 103 | 32 | 967196 | 97 | 30 |
| 964024 | 65 | 23 | 967212 | 75 | 9 |
| 964024 | 67 | 24 | 967249 | 103 | 36 |
| 964025 | 77 | 2 | 967324 | 65 | 65 |
| 964025 | 99 | 18 | 967337 | 79 | 25 |
| 964028 | 75 | 9 | 967338 | 99 | 12 |
| 964032 | 67 | 25 | 967340 | 75 | 8 |
| 964040 | 81 | 10 | 967340 | 87 | 20 |
| 964040 | 87 | 18 | 967341 | 69 | 16 |
| 964040 | 99 | 14 | 967342 | 65 | 66 |
| 964040 | 101 | 1 | 967342 | 67 | 26 |

| PART NO. | PAGE | REF |
|----------|------|-----|
| 967342 | 69 | 15 |
| 967342 | 95 | 8 |
| 967343 | 79 | 26 |
| 967350 | 99 | 15 |
| 967353 | 79 | 21 |
| 967353 | 85 | 15 |
| 967353 | 93 | 22 |
| 967353 | 103 | 29 |
| 967354 | 83 | 9 |
| 967354 | 97 | 31 |
| 967356 | 83 | 13 |
| 967357 | 95 | 5 |
| 967392 | 65 | 67 |
| 967393 | 99 | 8 |
| 967395 | 67 | 27 |
| 967396 | 67 | 4 |
| 968100 | 93 | 1 |
| N/A | 75 | 19 |
| N/A | 75 | 20 |
| N/A | 75 | 21 |
| N/A | 87 | 21 |
| N/A | 95 | 7 |

Use the diagram below to help you determine the slope of the terrain which is to be mowed. Never attempt to mow a slope of 15 degrees or more.

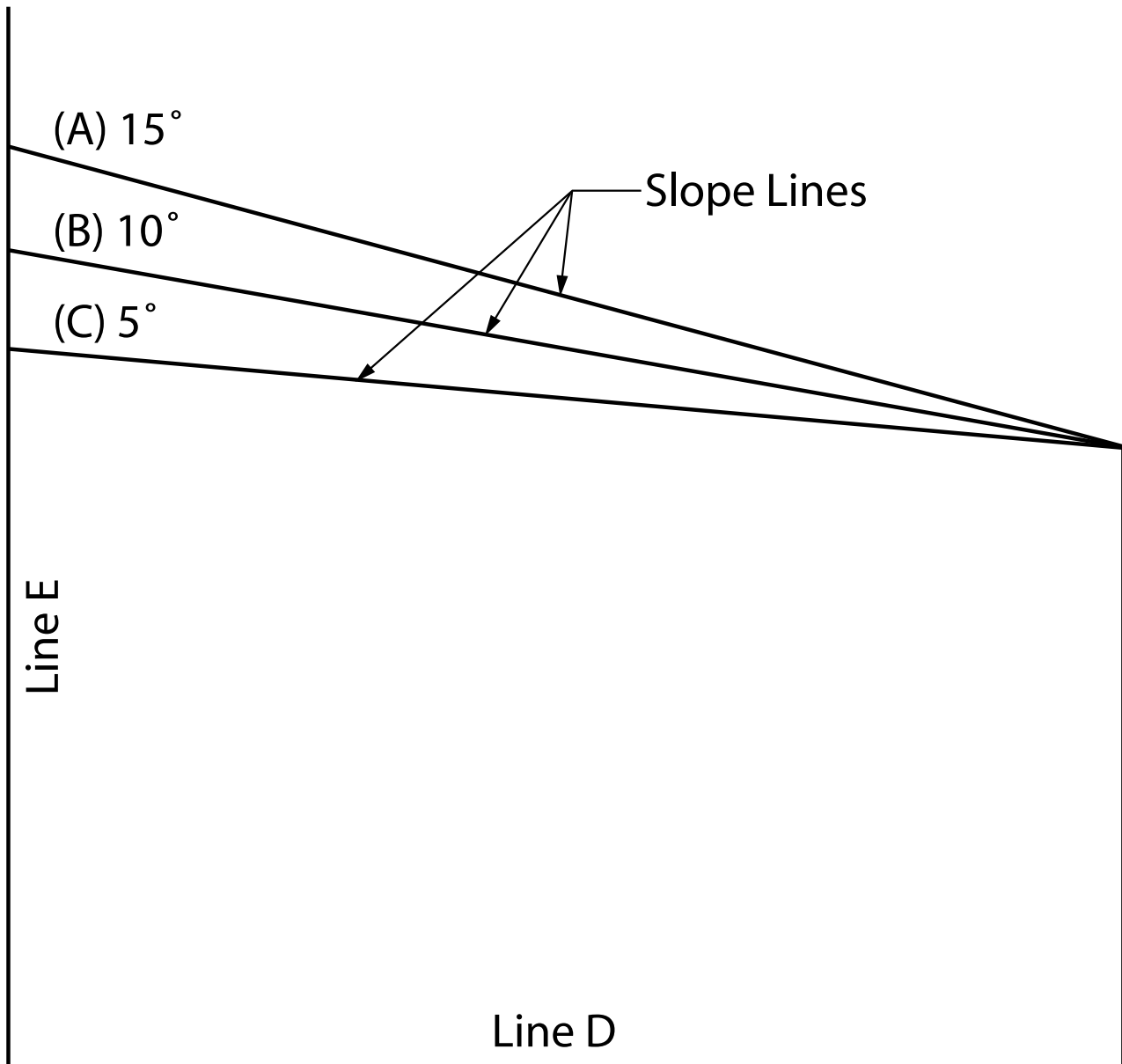

1. Cut this page out of the manual.
2. Hold the piece of paper so that Line D is horizontal.
3. Align Line E with a pole, tree, house or other vertical structure.
4. Fold the paper along the slope guide lines to find the closest line to match the slope of the terrain.

116 - MAINTENANCE RECORDS

Record dates of the services as they are performed for easy reference.

| Oil Filter and Engine Oil Change | Lubricate Machine | Air Cleaner Element Clean or Replace |
|----------------------------------|-------------------|--------------------------------------|
| | | |
| | | |
| | | |
| | | |
| | | |
| | | |
| | | |
| | | |
| | | |
| | | |
| | | |
| | | |
| | | |
| | | |
| | | |
| | | |
| | | |
| | | |
| | | |
| | | |
| | | |
| | | |
| | | |
| | | |
| | | |
| | | |
| | | |
| | | |
| | | |
| | | |
| | | |